

N-沟道超级结功率 MOS 管

SIF65R600

N-CHANNEL SUPER JUNCTION POWER MOSFET

●特点：新高压器件技术 低导通电阻和低传导损耗 封装小 超低栅极电荷导致较低的驱动要求
100%雪崩测试 符合RoHS规范

●FEATURES: ■NEW TECHNOLOGY FOR HIGH VOLTAGE DEVICE ■LOW ON-RESISTANCE AND LOW CONDUCTION LOSSES ■SMALL PACKAGE ■ULTRA LOW GATE CHARGE CAUSE LOWER DRIVING REQUIREMENTS ■100% AVALANCHE TESTED ■ROHS COMPLIANT

●应用：功率因数校正（PFC） 开关电源（SMPS） UPS 电源

●APPLICATION: ■POWER FACTOR CORRECTION (PFC) ■SWITCHED MODE POWER SUPPLIES(SMPS) ■UNINTERRUPTIBLE POWER SUPPLY (UPS)

●最大额定值（TC=25°C）

●Absolute Maximum Ratings（Tc=25°C） TO-220/220FP/262/263

参数 PARAMETER	符号 SYMBOL	额定值 VALUE	单位 UNIT
漏-源电压 Drain-source Voltage	V_{DS}	650	V
栅-源电压 gate-source Voltage	V_{GS}	±25	V
漏极电流 Continuous Drain Current TC=25°C	I_D	7	A
漏极电流 Continuous Drain Current TC=100°C	I_D	4	A
最大脉冲电流 Drain Current — Pulsed ①	I_{DM}	23	A
耗散功率 Power Dissipation	P_D	Others: 63 220FP: 28	W
最高结温 Junction Temperature	T_j	150	°C
存储温度 Storage Temperature	T_{STG}	-55-150	°C
漏源电压斜率 Drain Source voltage slope	dV/dt	50	V/ns
单脉冲雪崩能量 Single Pulse Avalanche Energy ②	E_{AS}	65	mJ

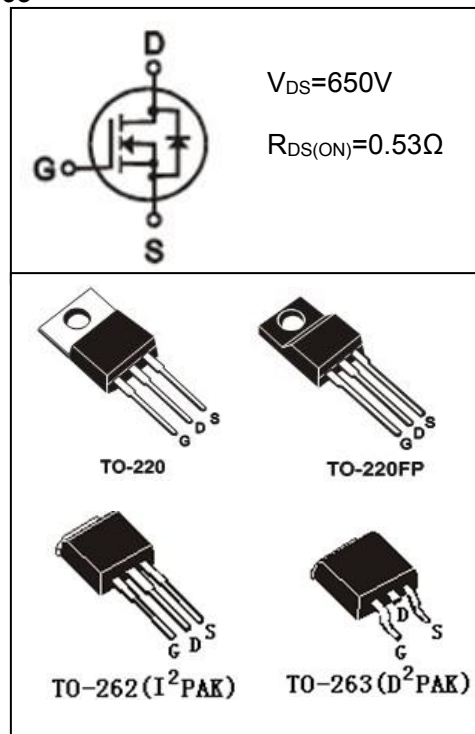

●热特性

●Thermal Characteristic

参数 PARAMETER	符号 SYMBOL	最大值 MAX		单位 UNIT
		TO-220/TO-262,263	TO-220FP	
热阻结-壳 Thermal Resistance Junction-case	R_{thJC}	1.98	4.46	°C/W
热阻结-环境 Thermal Resistance Junction-ambient	R_{thJA}	62	62.5	°C/W

●订单信息/ORDERING INFORMATION:

包装形式/PACKING	订货编码/ORDERING CODE	
	普通塑封料/ Normal Package Material	无卤塑封料/Halogen Free
TO-220 条管装/TUBE PACKING	SIF65R600 TO-220-TU	SIF65R600 TO-220-TU-HF
TO-220FP 条管装/TUBE PACKING	SIF65R600 TO-220FP-TU	SIF65R600 TO-220FP-TU-HF
TO-262 或 263 条管装/TUBE PACKING	SIF65R600 TO-262-TU 或 SIF65R600 TO-263-TU	SIF65R600 TO-262-TU-HF 或 SIF65R600 TO-263-TU-HF
TO-263 编带装/TAPE & REEL PACKING	SIF65R600 TO-263-TR	SIF65R600 TO-263-TR-HF

N-沟道超级结功率 MOS 管

SIF65R600

N-CHANNEL SUPER JUNCTION POWER MOSFET

电特性 (Tc=25°C)

● Electronic Characteristics (Tc=25°C)

参数 PARAMETER	符号 SYMBOL	测试条件 TEST CONDITION	最小值 MIN	典型值 TYP	最大值 MAX	单位 UNIT
漏-源击穿电压 Drain-source Breakdown Voltage	BV _{DSS}	V _{GS} =0V, I _D =250μA	650			V
漏-源漏电流 Drain-source Leakage Current	I _{DSS}	V _{DS} =650V, V _{GS} =0V, T _J =25°C			1	μA
栅极漏电流 Gate-body Leakage Current (V _{DS} = 0)	I _{GSS}	V _{GS} =±30V			±100	nA
栅极开启电压 Gate Threshold Voltage	V _{GS(TH)}	V _{GS} =V _{DS} , I _D =250μA	2.0		4.0	V
漏-源导通电阻 Static Drain-source On Resistance	R _{DS(ON)}	V _{GS} =10V, I _D =4A		0.53	0.62	Ω
跨导 Forward Transconductance	g _{fs}	V _{DS} =10V, I _D =4A		7		S
输入电容 Input Capacitance	C _{iss}	V _{GS} = 0V, V _{DS} = 25V F = 1.0MHZ		560		pF
输出电容 Output Capacitance	C _{oss}			425		
反向传输电容 Reverse transfer Capacitance	C _{rss}			32		
栅极电荷 Total Gate Charge	Q _g	I _D =8A, V _{DS} = 10V V _{GS} = 10V		11.3		nC
栅源电荷 Gate-to-Source Charge	Q _{gs}			2.8		nC
栅漏电荷 Gate-to-Drain Charge	Q _{gd}			2.8		nC
栅电阻 Intrinsic Gate Resistance	R _G	f=1MHz open drain		7.5		Ω
开启延迟 Turn -on Delay Time	T _{d(on)}	V _{DD} =380V, I _D =8A R _G =20 Ω V _{GS} =10V		18		ns
上升时间 Turn -on Rise Time	t _r			18		ns
关断延迟 Turn -Off Delay Time	T _{d(off)}			27		ns
下降时间 Turn -Off Fall Time	t _f			22		ns
二极管正向电流 Continuous Diode Forward Current	I _{SD}	TC=25°C			7	A
二极管正向压降 Diode Forward Voltage	V _{SD}	T _J =25°C, I _{SD} =5.0A V _{GS} =0V		0.7	1.3	V
反向恢复时间 Reverse Recovery Time	t _{rr}	T _J =25°C, V _R =380V I _F =7A di _F /dt=100A/ μ s		211		ns
反向恢复电荷 Reverse Recovery Charge	Q _{rr}			1.8		uC
反向恢复电流峰值 Peak Reverse Recovery Current	I _{rrm}			10.5		A

注释(Notes):

① 脉冲宽度: 以最高节温为限制

Repetitive rating: Pulse width limited by maximum junction temperature

② EAS测试条件: VDD=50V RG=25 Ω L=3mH ID=7A, T_J=25°C

EAS Test condition: VDD=50V RG=25 Ω L=3mH ID=7A, T_J=25°C

N-沟道超级结功率 MOS 管
N-CHANNEL SUPER JUNCTION POWER MOSFET

SIF65R600

● 特性曲线 Characteristic curve



图 1 最大安全工作区曲线 (TO-220/262/263)
Fig1 Maximum Safe Operating Area (TO-220/262/263)



图 2 最大安全工作区曲线 (TO-220FP)
Fig2 Maximum Safe Operating Area

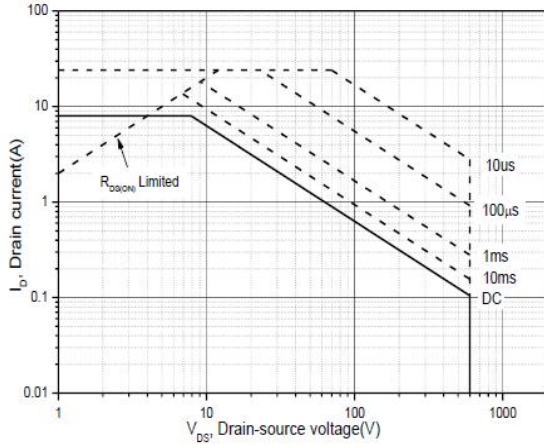

图 3 输出特性曲线, Tc=25°C
Fig3 Typical Output Characteristics

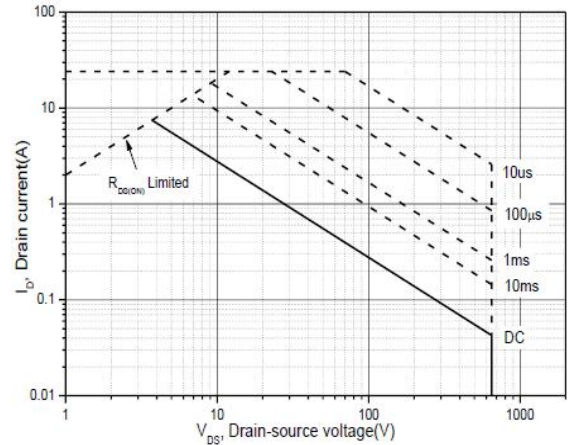

图 4 输出特性曲线, Tc=150°C
Fig4 Typical Output Characteristics

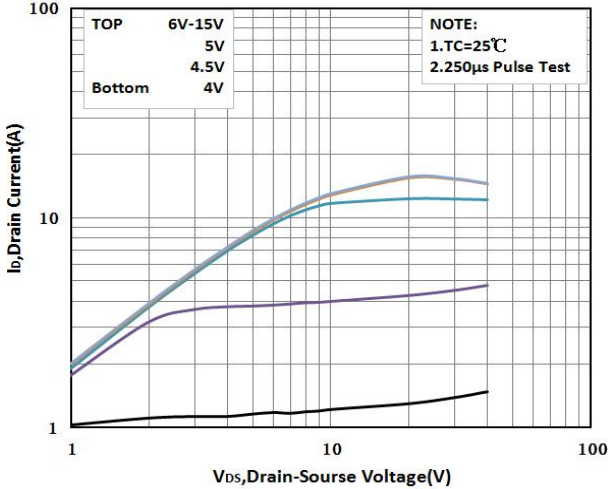

图 5 静态导通电阻与电流曲线
Fig5 Static drain-source On-Resistance

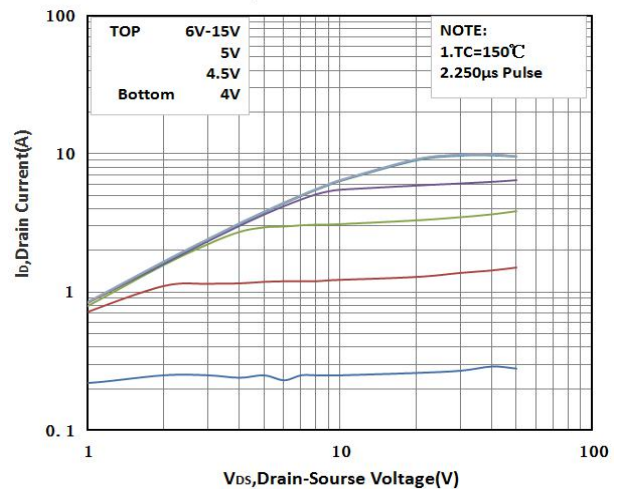

图 6 导通电阻与结温曲线
Fig6 R_DS(on) VS Junction Temperature

N-沟道超级结功率 MOS 管
N-CHANNEL SUPER JUNCTION POWER MOSFET

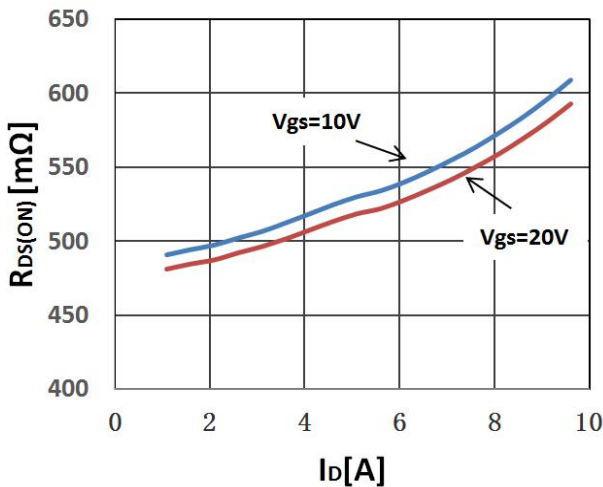
SIF65R600

● 特性曲线 Characteristic curve

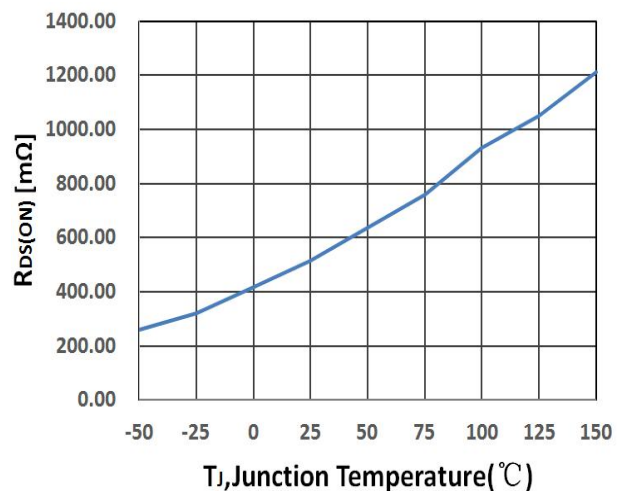

图 7 栅电荷与 VGS 关系曲线

Fig7 Gate Charge waveforms

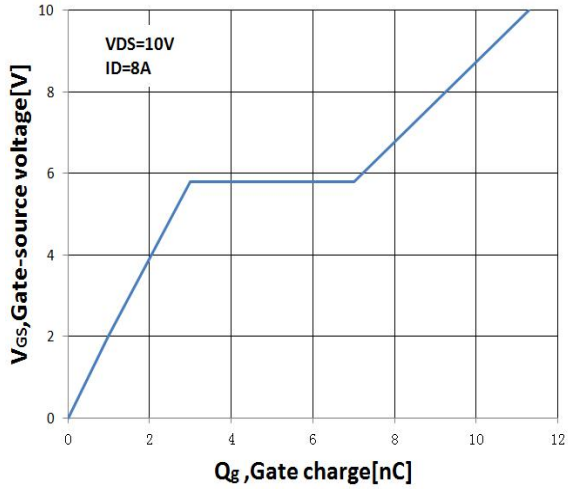

图 8 电容与漏源电压关系曲线

Fig8 Capacitance

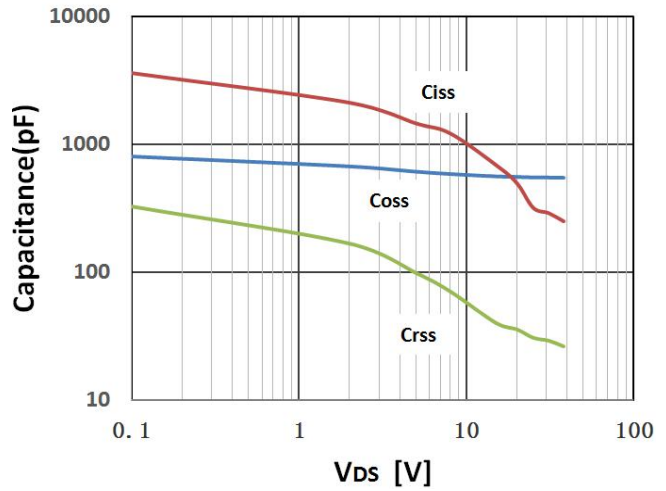

图 9 二极管正向电压曲线

Fig9 Typical Source-Drain Diode Forward Voltage

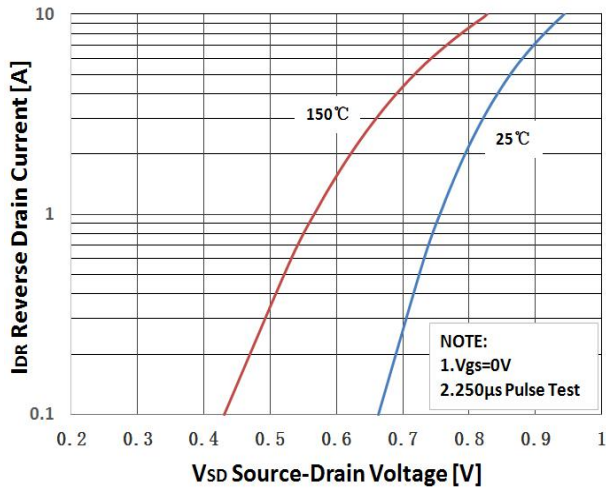

图 10 传输特性曲线

Fig10 Transfer Characteristics

TO-220 封装机械尺寸 TO-220 MECHANICAL DATA

单位：毫米/UNIT: mm

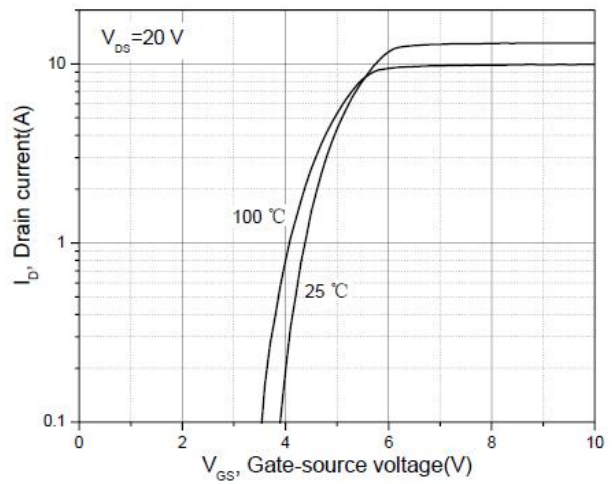
符号 SYMBOL	最小值 min	典型值 nom	最大值 max	符号 SYMBOL	最小值 min	典型值 nom	最大值 max
A	4.00		4.80	E	9.90		10.70
B	1.20		1.50	e		2.54	
B1	1.00		1.40	F	1.10		1.45
b1	0.65		1.00	L	12.50		14.50
c	0.35		0.75	L1	3.00	3.50	4.00
D	15.00		16.50	Q	2.50		3.00
D1	5.90		6.90	Q1	2.00		3.00
				φP	3.50		3.90

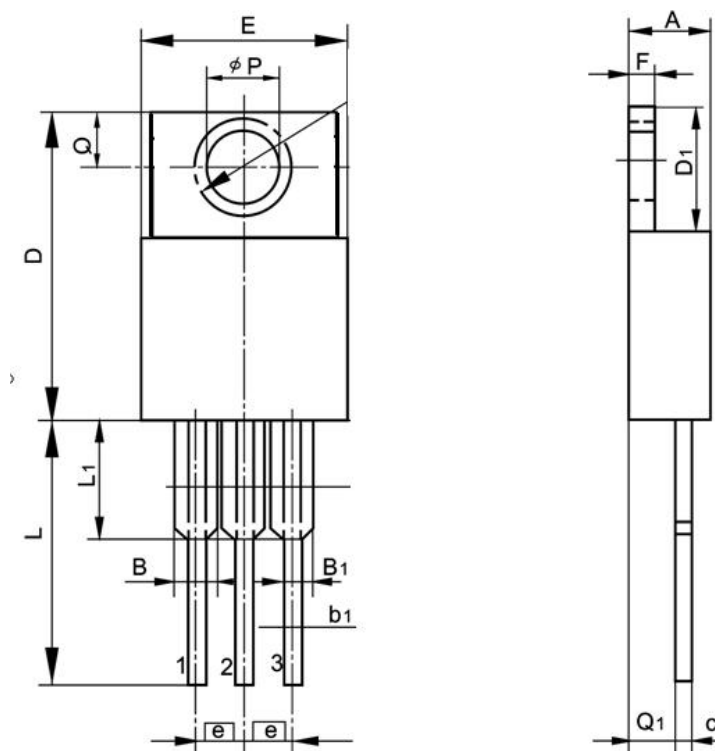

TO-220FP 封装机械尺寸 TO-220FP MECHANICAL DATA

单位:毫米/UNIT: mm

符号 SYMBOL	最小值 min	典型值 nom	最大值 max	符号 SYMBOL	最小值 min	典型值 nom	最大值 max
A	4.40		4.95	E	9.60		10.30
A ₁	2.30		2.90	e		2.54	
b	0.70		0.90	L	12.40		14.00
b ₁	1.18		1.45	L₂	2.30		2.60
c	0.40		0.70	L ₃	3.00		4.00
D	14.50		17.00	øp	3.00		3.50
D1	6.10		9.00	Q	2.30		2.80

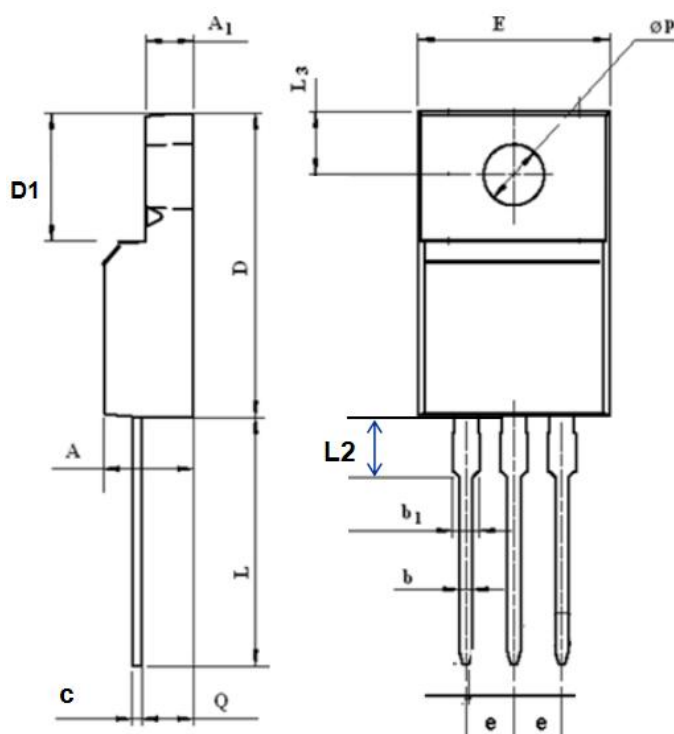

TO-262 封装机械尺寸 TO-262 MECHANICAL DATA

单位：毫米/UNIT: mm

符号 SYMBOL	最小值 min	典型值 nom	最大值 max	符号 SYMBOL	最小值 min	典型值 nom	最大值 max
A	3.80		4.80	e		2.54	
A1	2.00		2.80	e1			5.30
b	0.60		1.00	E	9.90		10.70
b1	1.20		1.40	L	12.50		14.50
c	0.40		0.70	L1	0.80	1.00	1.20
c2	1.10		1.40	L2			1.50
D			9.60				

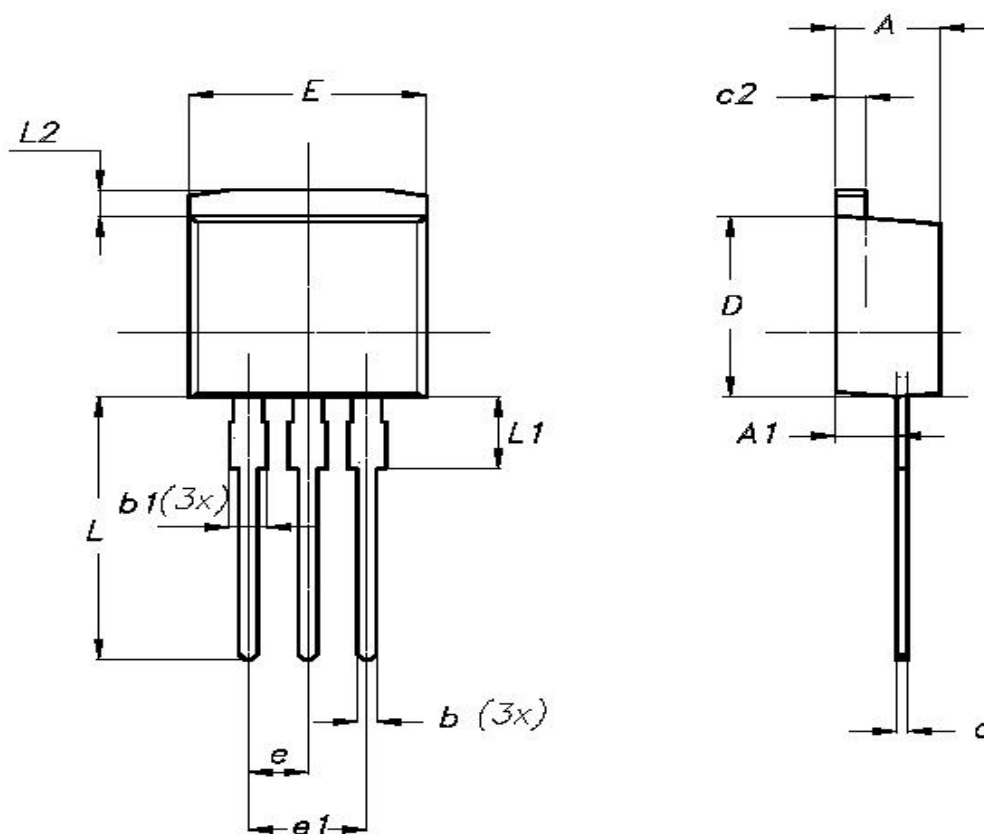

TO-263 封装机械尺寸

TO-263(D2PAK) MECHANICAL DATA

单位：毫米/UNIT: mm

符号 SYMBOL	最小值 min	典型值 nom	最大值 max	符号 SYMBOL	最小值 min	典型值 nom	最大值 max
A	4.42		4.72	E	8.99		9.29
B	1.22		1.32	e1	2.44		2.64
b	0.76		0.86	e2	4.98		5.18
b1	1.22		1.32	L1	15.19		15.79
b2	0.33		0.43	L2	2.29		2.79
C	1.22		1.32	L3	1.30		1.75
D	9.95		10.25				

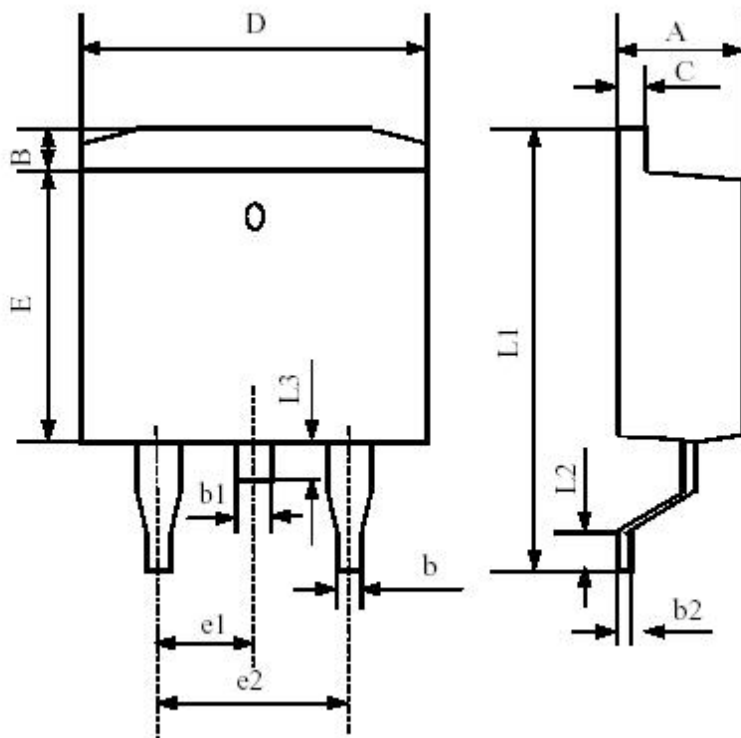

TO-263 编带规格尺寸 TO-263 TAPE AND REEL DATA

单位:毫米/UNIT: mm

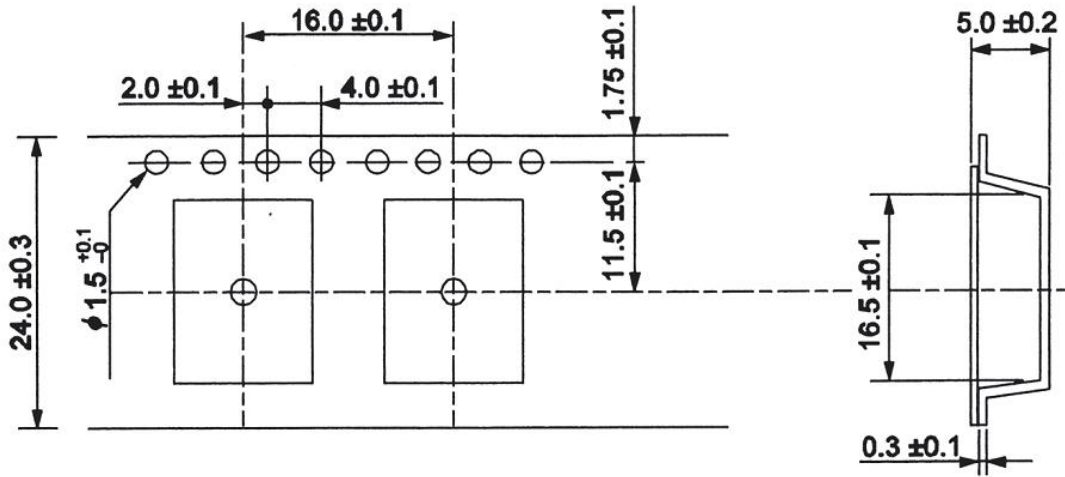

使用供带方向/USER DIRECTION OF FEED

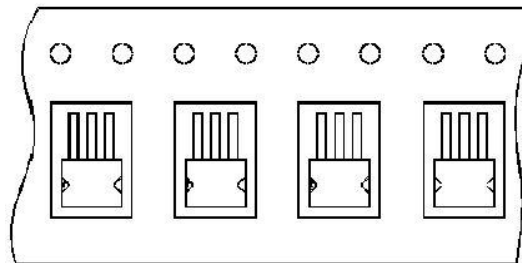

编带器件定位示意图/UNIT ORIENTATION