

N-沟道功率 MOS 管/ N-CHANNEL POWER MOSFET

SIF50N060

- 特点: 热阻低 导通电阻低 栅极电荷低, 开关速度快 输入阻抗高 符合RoHS规范
- FEATURES: ■LOW THERMAL RESISTANCE ■LOW $R_{DS(ON)}$ TO MINIMIZE CONDUCTIVE LOSS ■LOW GATE CHARGE FOR FAST SWITCHING ■HIGH INPUT RESISTANCE ■RoHS COMPLIANT
- 应用: 低压高频逆变电路 同步整流 开关
- APPLICATION: ■LOW VOLTAGE,HIGH FREQUENCY INVERTERS ■SYNCHRONOUS RECTIFIER ■PRIMARY SWITCH

●最大额定值 (TC=25°C)

●Absolute Maximum Ratings (Tc=25°C) TO-251T/251S/252/252T

参数 PARAMETER	符号 SYMBOL	额定值 VALUE	单位 UNIT
漏-源电压 Drain-source Voltage	V_{DS}	60	V
栅-源电压 gate-source Voltage	V_{GS}	±20	V
漏极电流 Continuous Drain Current TC=25°C ①	I_D	50*	A
耗散功率 Total Power Dissipation ①	P_{tot}	46*	W
最高结温 Junction Temperature	T_j	150	°C
存储温度 Storage Temperature	T_{STG}	-55-175	°C
单脉冲雪崩能量 Single Pulse Avalanche Energy ②	E_{AS}	88	mJ

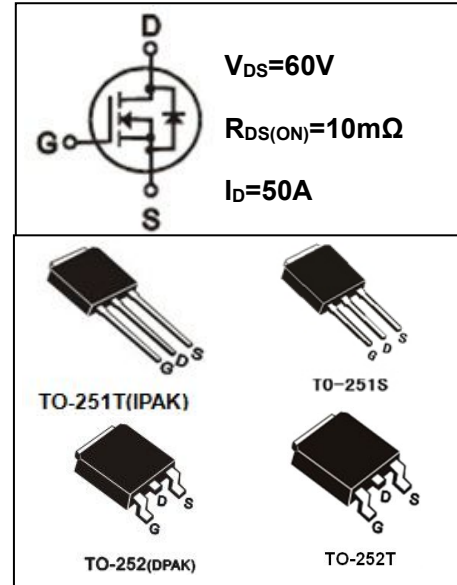

●电特性 (Tc=25°C)

●Electronic Characteristics (Tc=25°C)

参数 PARAMETER	符号 SYMBOL	测试条件 TEST CONDITION	最小值 MIN	典型值 TYP	最大值 MAX	单位 UNIT
漏-源击穿电压 Drain-source Breakdown Voltage	BV_{DSS}	$V_{GS}=0V, I_D=250\mu A$	60	68		V
栅极开启电压 Gate Threshold Voltage	$V_{GS(TH)}$	$V_{GS}=V_{DS}, I_D=250\mu A$	1.2	1.8	2.2	V
漏-源漏电流 Drain-source Leakage Current	I_{DSS}	$V_{DS}=60V, V_{GS}=0V, T_j=25^\circ C$			1	μA
		$V_{DS}=60V, V_{GS}=0V, T_j=125^\circ C$			10	μA
栅极漏电流 Gate-body Leakage Current	I_{GSS}	$V_{GS}=\pm 20V, V_{DS}=0V$			±100	nA
漏-源导通电阻 Static Drain-source On Resistance	$R_{DS(ON)}$	$V_{GS}=10V, I_D=9A$		10	13	mΩ
		$V_{GS}=4.5V, I_D=6A$		12	15	
跨导 Forwad Transconductance	g_{FS}	$V_{DS}=5V, I_D=9A$	18			S

●订单信息/ORDERING INFORMATION:

包装形式/PACKING	订货编码/ORDERING CODE	
	普通塑封料 Normal Package Material	无卤塑封料 Halogen Free
TO-252(T)&251T&251S 条管装 TUBE PACKING	SIF50N060 TO-251T-TU 或 TO-251S-TU 或 TO-252(T)-TU	SIF50N060 TO-251T-TU-HF 或 TO-251S-TU-HF 或 TO-252(T)-TU-HF
TO-252(T) 编带装/TAPE & REEL PACKING	SIF50N060 TO-252(T)-TR	SIF50N060 TO-252(T)-TR-HF

N-沟道功率 MOS 管/ N-CHANNEL POWER MOSFET

SIF50N060

参数 PARAMETER	符号 SYMBOL	测试条件 TEST CONDITION	最小值 MIN	典型值 TYP	最大值 MAX	单位 UNIT
输入电容 Input Capacitance	Ciss	$V_{GS} = 0V, V_{DS} = 30V$ $F = 1.0MHz$		2180		pF
输出电容 Output Capacitance	Coss			172		
反向传输电容 Reverse Transfer Capacitance	Crss			142		
栅极电荷 Total Gate Charge	Qg	$I_D = 8A, V_{DS} = 30V$ $V_{GS} = 10V$		58		nC
栅源电荷 Gate-to-Source Charge	Qgs			8		nC
栅漏电荷 Gate-to-Drain Charge	Qgd			17		nC
栅极开启电荷量 Gate Charge At Threshold	Qg(th)			6		nC
导通延迟 Turn -On Delay Time	Td(on)	$V_{DD}=30V, R_L=1\Omega$ $V_{GS} = 10V, R_{GEN}=3\Omega$		8.5		ns
开启上升时间 Turn -On Rise Time	T _r			6		ns
关断延迟 Turn -Off Delay Time	Td(off)			30		ns
关断下降时间 Turn -Off Fall Time	T _f			5		ns
二极管正向压降 Diode Forward Voltage	V _{SD}	$T_j=25^\circ C, I_F=9A$ $V_{GS} = 0V$ ③		0.8	1.2	V
反向恢复时间 Reverse Recovery Time	t _{rr}	$I_f=9A, di/dt=100A/\mu s$ $T_j=25^\circ C, \text{③}$		30		ns
反向恢复电荷 Reverse Recovery Charge	Q _{rr}			44		nC

●热特性

●Thermal Characteristics

参数 PARAMETER	符号 SYMBOL	最大值 MAX	单位 UNIT
热阻结-壳 Thermal Resistance Junction-case	R _{thJC}	2.78	°C/W

注释(Notes):

- ① 以最高结温为限制， T_c=25°C时测试。
I_D & P_D base on maximum allowable junction temperature, test at T_c=25°C.
- ② 初始结温=25°C, L=0.1mH.
Starting T_j=25°C, L=0.1mH
- ③ 脉冲测试: 脉冲宽度 ≤ 300μs , 占空比 ≤ 2%
Pulse Test : Pulse width ≤ 300μs, Duty cycle ≤ 2%

N-沟道功率 MOS 管/ N-CHANNEL POWER MOSFET

SIF50N060

● 特性曲线

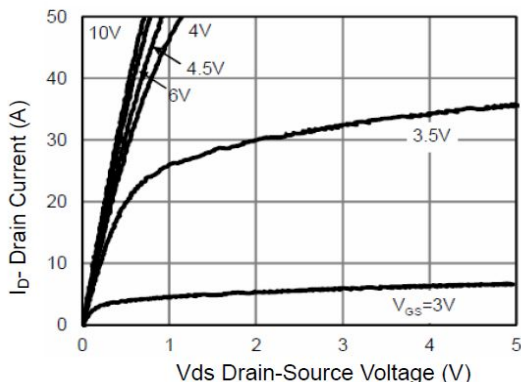

Figure 1 Output Characteristics

图 1 输出特性曲线, $T_c=25^\circ\text{C}$

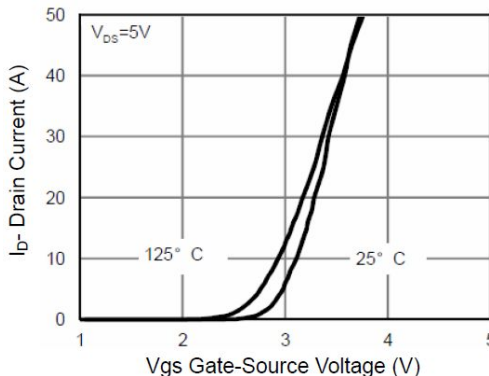

Figure 2 Transfer Characteristics

图 2 转移特性曲线

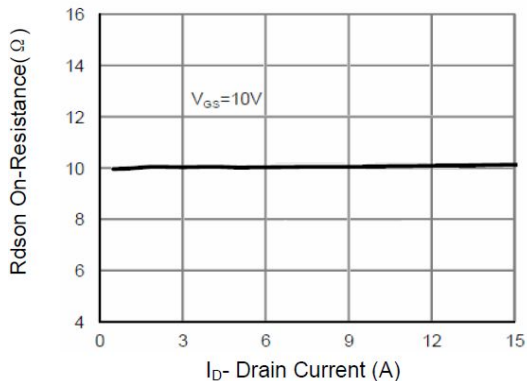

Figure 3 $R_{DS(on)}$ - Drain Current

图 3 导通电阻与漏极电流 曲线

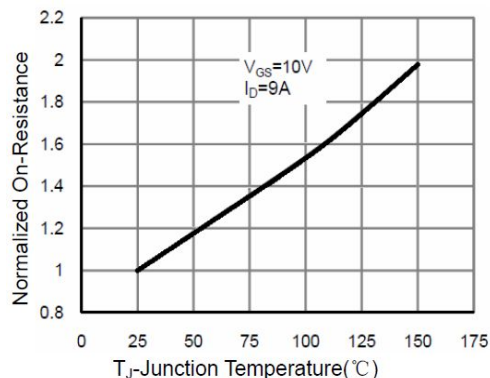

Figure 4 $R_{DS(on)}$ -Junction Temperature

图 4 导通电阻与结温度 曲线

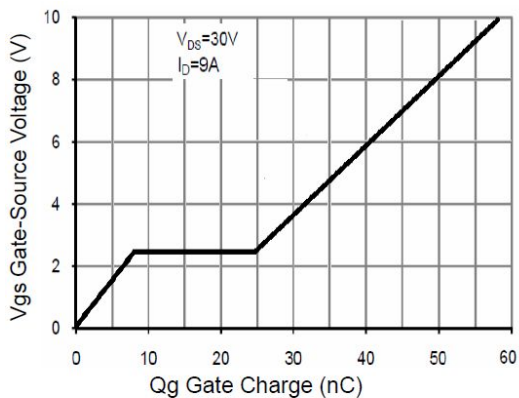

Figure 5 Gate Charge

图 5 栅电荷 曲线

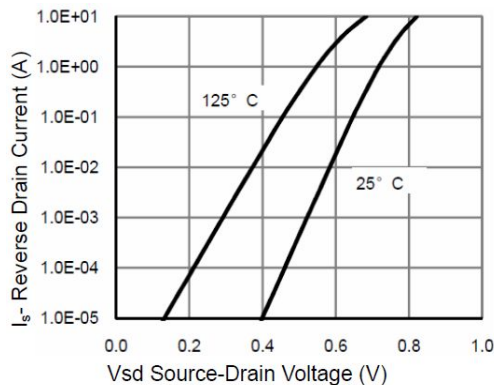

Figure 6 Source- Drain Diode Forward

图 6.二极管正向压降与源极电流 曲线

N-沟道功率 MOS 管/ N-CHANNEL POWER MOSFET

SIF50N060

● 特性曲线

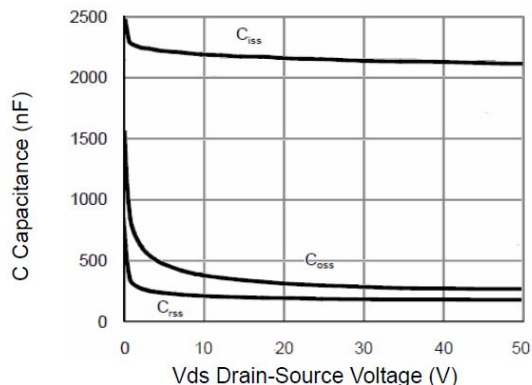

Figure 7 Capacitance vs Vds

图 7 电容特性曲线

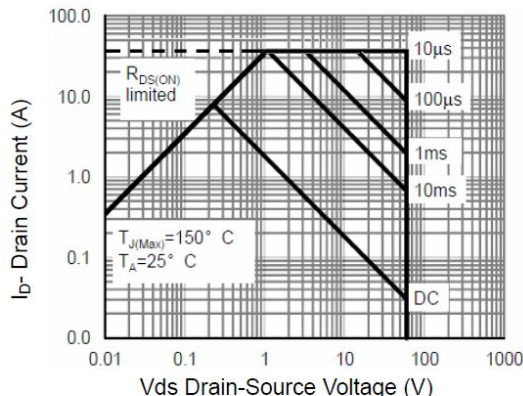

Figure 8 Safe Operation Area

图 8 SOA 曲线

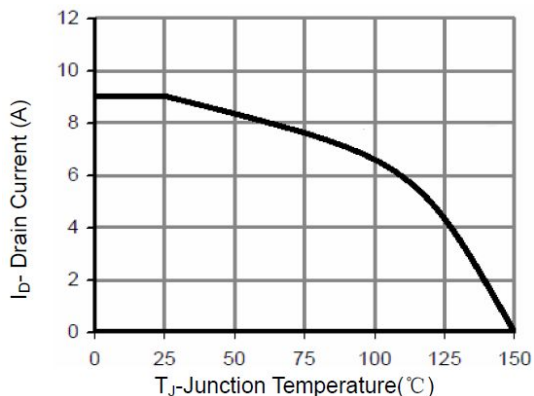

Figure 9 Current De-rating

图 9 电流-温度曲线

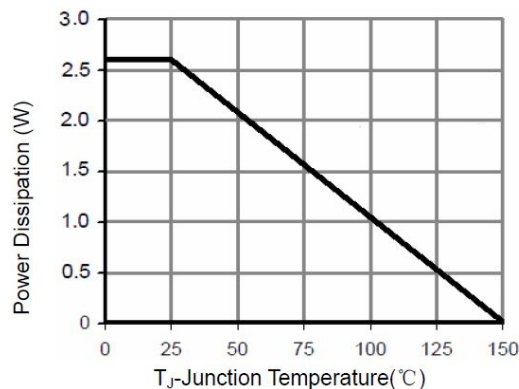

Figure 10 Power De-rating

图 10 耗散功率-温度 曲线

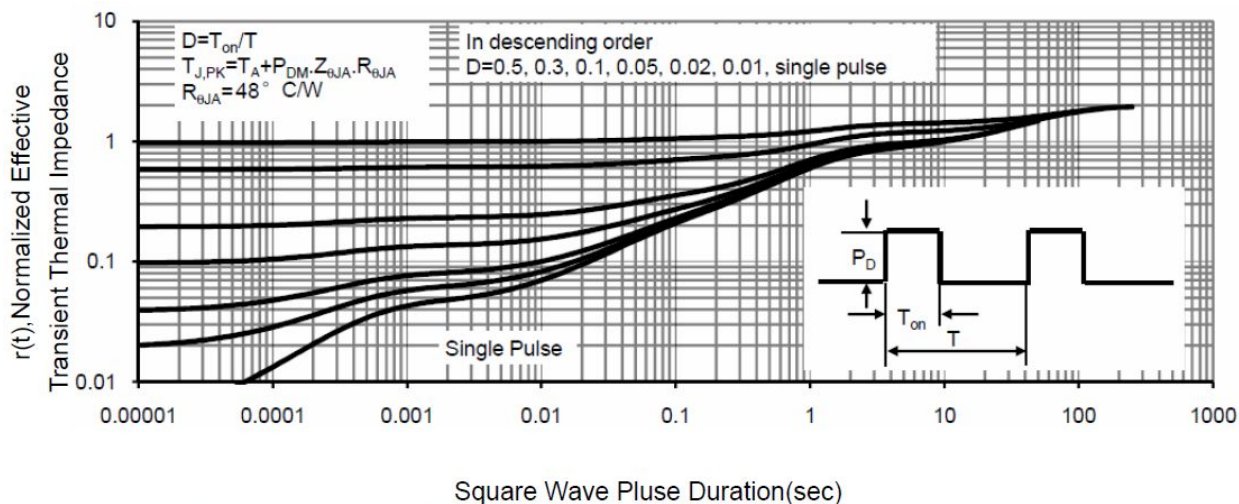

Figure 11 Normalized Maximum Transient Thermal Impedance

图 11 标准化瞬态热阻曲线

TO-251T 封装机械尺寸 TO-251T (IPAK) MECHANICAL DATA

单位:毫米/UNIT: mm

符号/SYMBOL	最小值/min	典型值/nom	最大值/max
A	2.10		2.50
A ₁	0.95		1.30
B	0.80		1.25
b	0.50		0.80
b ₁	0.70		0.80
c	0.45		0.70
c ₁	0.45		0.70
D	6.35		6.80
D ₁	5.10		5.50
E	5.30		6.30
e	2.25	2.30	2.35
L	7.00		9.20
H	0.35		0.45
W ₁	0.30		0.50
W ₂	0.20		0.40

[S/L]

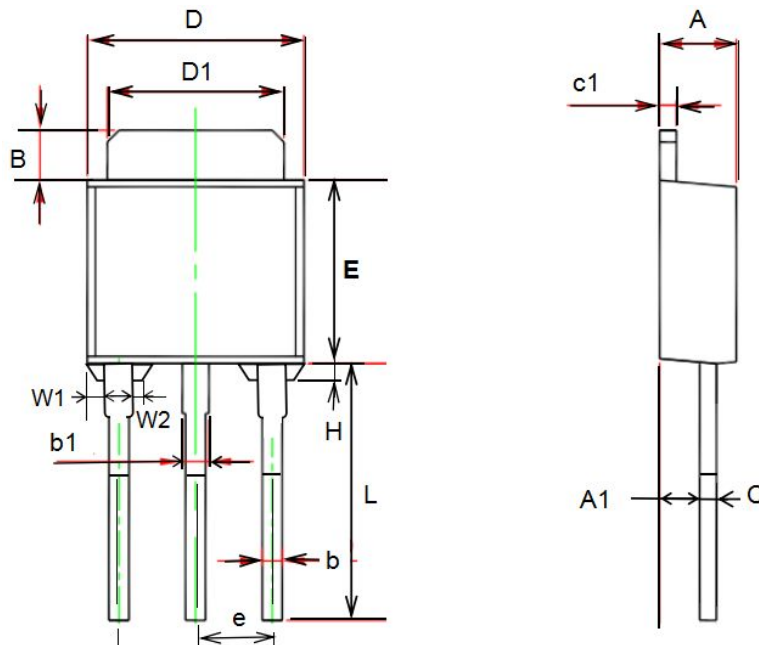

TO-251S 封装机械尺寸 TO-251S (IPAK) MECHANICAL DATA

单位:毫米/UNIT: mm

符号/SYMBOL	最小值/min	典型值/nom	最大值/max
A	2.20		2.40
b	0.50		0.85
C	0.45	0.50	0.60
D	6.50		6.70
D1	5.10		5.50
E	5.9		6.20
e	2.18	2.29	2.38
L	11.00		12.40
L1	4.8		5.3
L2	3.5		4.2

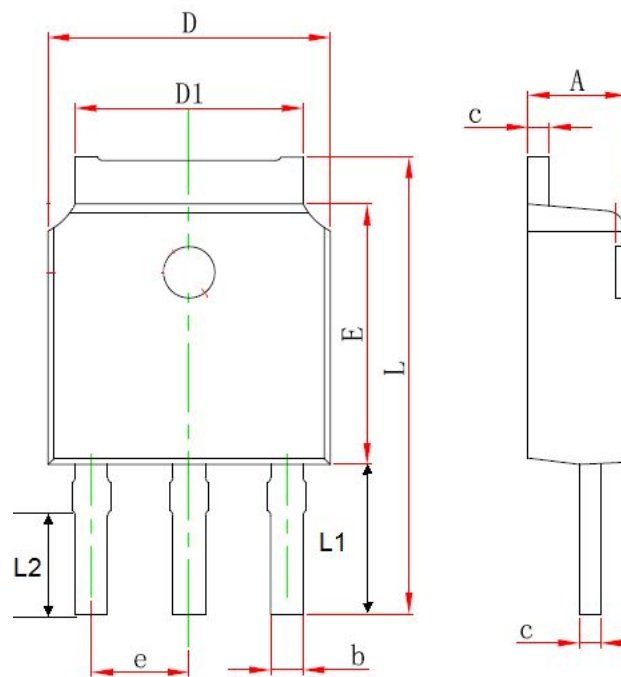

TO-252 封装机械尺寸 TO-252 MECHANICAL DATA

单位:毫米/UNIT: mm

符号 SYMBOL	最小值 min	最大值 max	符号 SYMBOL	最小值 min	最大值 max
A	2.10	2.50	B	0.85	1.25
b	0.50	0.80	b1	0.70	1.20
b2	0.45	0.70	C	0.45	0.70
D	6.30	6.75	D1	5.10	5.50
E	5.30	6.30	e1	2.25	2.35
L1	9.20	10.60	e2	4.45	4.75
L2	0.90	1.75	L3	0.60	1.10
K	0.00	0.23			

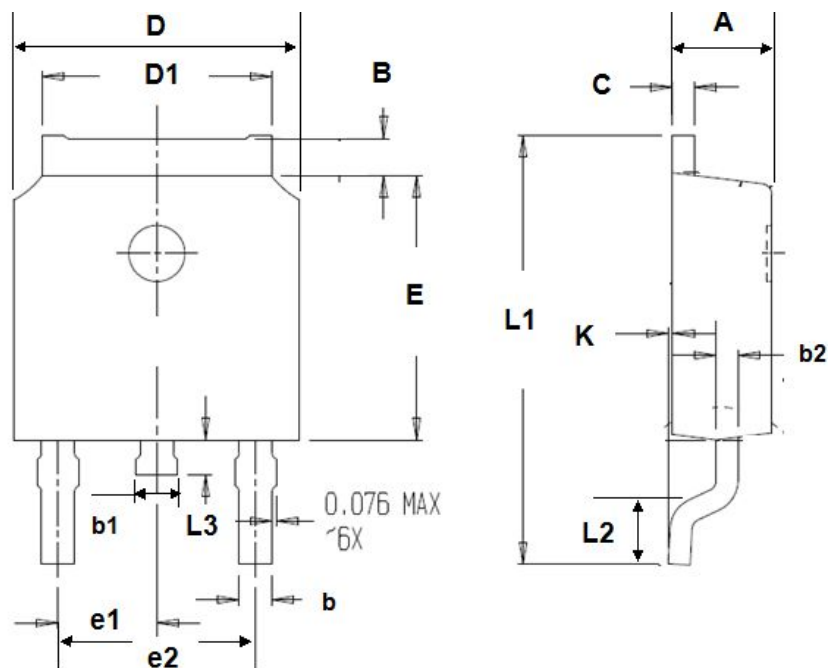

TO-252T 封装机械尺寸 TO-252T MECHANICAL DATA

单位:毫米/UNIT: mm

符号 SYMBOL	最小值 min	最大值 max	符号 SYMBOL	最小值 min	最大值 max
A	2.20	2.40	B	0.85	1.25
b	0.50	0.80	C	0.45	0.70
b1	0.45	0.70	D	6.30	6.70
D1	5.10	5.50	E	5.30	6.20
L1	9.20	10.60	F	0.50	0.90
L2	0.90	1.50	e1	2.25	2.35
L3	0.60	1.10	e2	4.50	4.70
			K	0.00	0.18

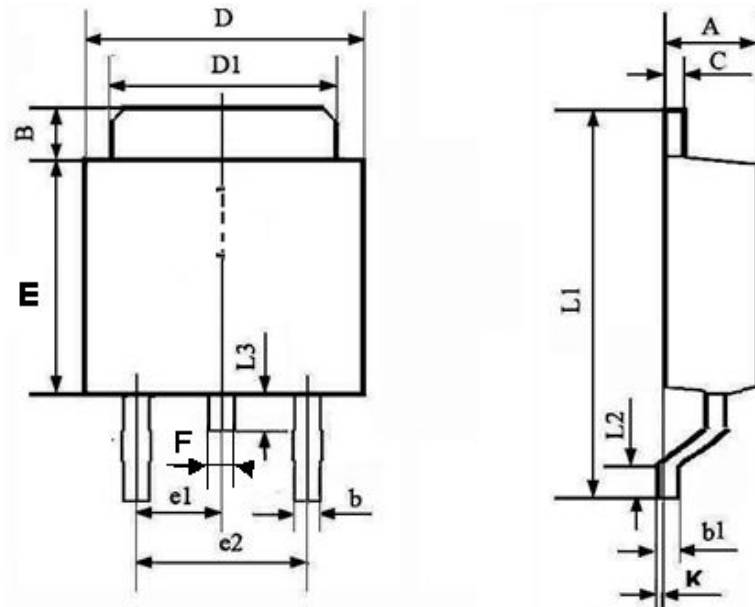

[L]

TO-252 编带规格尺寸 TO-252 TAPE AND REEL DATA

单位:毫米/UNIT: mm

符号 SYMBOL	最小值 min	典型值 nom	最大值 max	符号 SYMBOL	最小值 min	典型值 nom	最大值 max
A0	6.80	6.90	7.00	B0	10.40	10.50	10.60
K0	2.60	2.70	2.90	K1	2.40	2.50	2.60
F	7.40	7.50	7.60	K2	1.60	1.70	1.80
W	15.90	16.00	16.10	P1	7.90	8.00	8.10

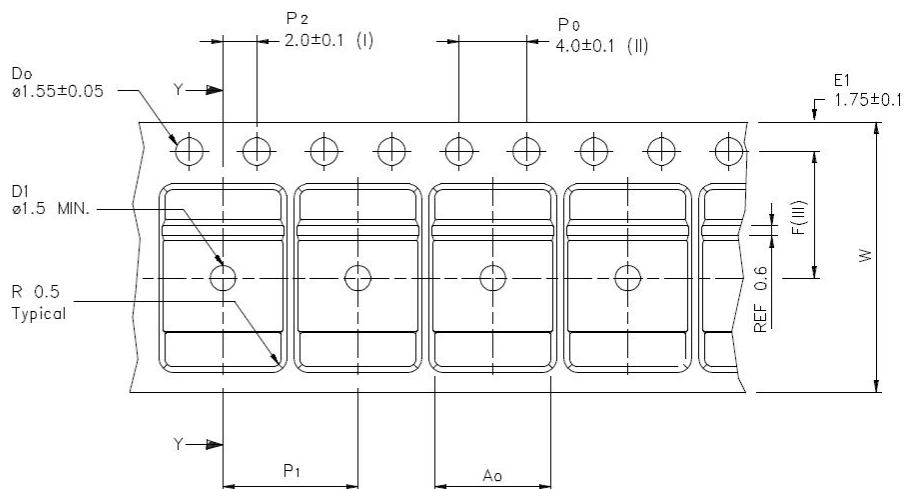
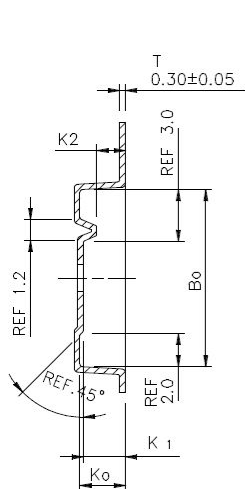

使用供带方向/USER DIRECTION OF FEED

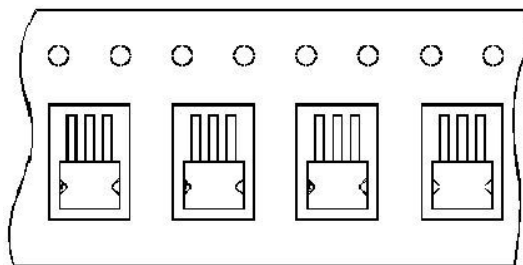

编带器件定位/UNIT ORIENTATION