

N-沟道功率 MOS 管/ N-CHANNEL POWER MOSFET

SIF2N60FB

- 特点：导通电阻低 开关速度快 输入阻抗高 符合RoHS规范
- FEATURES: ■LOW ON-RESISTANCE ■FAST SWITCHING ■HIGH INPUT RESISTANCE ■RoHS COMPLIANT
- 应用：电子镇流器 电子变压器 开关电源
- APPLICATION: ■ELECTRONIC BALLAST ■ELECTRONIC TRANSFORMER ■SWITCH MODE POWER SUPPLY
- 最大额定值 (Tc=25°C)

●Absolute Maximum Ratings (Tc=25°C) TO-220/220FP/262/263

参数 PARAMETER	符号 SYMBOL	额定值 VALUE	单位 UNIT
漏-源电压 Drain-source Voltage	V <sub>DS</sub>	600	V
栅-源电压 gate-source Voltage	V <sub>GS</sub>	±30	V
漏极电流 Continuous Drain Current TC=25°C	I <sub>D</sub>	2.0	A
漏极电流 Continuous Drain Current TC=100°C	I <sub>D</sub>	1.25	A
最大脉冲电流 Drain Current - Pulsed ①	I <sub>DM</sub>	8	A
耗散功率 Power Dissipation	P <sub>tot</sub>	TO-220:54	W
		TO-220FP:23	
		TO-262/263:54	
最高结温 Junction Temperature	T <sub>j</sub>	150	°C
存储温度 Storage Temperature	T <sub>STG</sub>	-55-150	°C
单脉冲雪崩能量 Single Pulse Avalanche Energy②	E <sub>AS</sub>	72	mJ

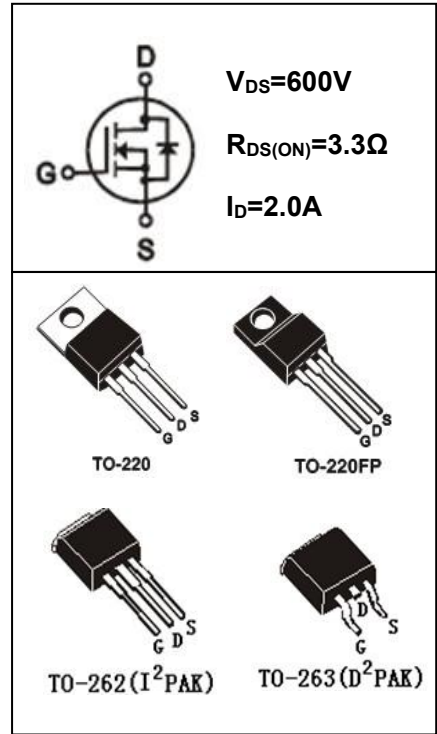

●电特性 (Tc=25°C)

●Electronic Characteristics (Tc=25°C)

参数 PARAMETER	符号 SYMBOL	测试条件 TEST CONDITION	最小值 MIN	典型值 TYP	最大值 MAX	单位 UNIT
漏-源击穿电压 Drain-source Breakdown Voltage	BV <sub>DSS</sub>	V <sub>GS</sub> =0V, I <sub>D</sub> =250μA	600			V
击穿电压温度系数 Breakdown Voltage Temperature Coefficient	ΔBV <sub>DSS</sub> /ΔT <sub>j</sub>	I <sub>D</sub> =250uA, Referenced to 25°C		0.6		V/°C
栅极开启电压 Gate Threshold Voltage	V <sub>GS(TH)</sub>	V <sub>GS</sub> =V <sub>DS</sub> , I <sub>D</sub> =250μA	2.0		4.0	V
漏-源漏电流 Drain-source Leakage Current	I <sub>DSS</sub>	V <sub>DS</sub> =600V, V <sub>GS</sub> =0V, T <sub>j</sub> =25°C			1	μA
		V <sub>DS</sub> =480V, V <sub>GS</sub> =0V, T <sub>j</sub> =125°C			100	μA
跨导 Forward Transconductance	g <sub>fs</sub>	V <sub>DS</sub> =15V, I <sub>D</sub> =1A ③		2.5		S

●订单信息/ORDERING INFORMATION:

包装形式/PACKING	订货编码/ORDERING CODE	
	普通塑封料/ Normal Package Material	无卤塑封料/Halogen Free
TO-220 条管装/TUBE PACKING	SIF2N60FB TO-220-TU	SIF2N60FB TO-220-TU-HF
TO-220FP 条管装/TUBE PACKING	SIF2N60FB TO-220FP-TU	SIF2N60FB TO-220FP-TU-HF
TO-262 或 263 条管装/TUBE PACKING	SIF2N60FB TO-262-TU 或 SIF2N60FB TO-263-TU	SIF2N60FB TO-262-TU-HF 或 SIF2N60FB TO-263-TU-HF
TO-263 编带装/TAPE&REEL PACKING	SIF2N60FB TO-263-TR	SIF2N60FB TO-263-TR-HF

N-沟道功率MOS管/N-CHANNEL POWER MOSFET

SIF2N60FB

参数 PARAMETER	符号 SYMBOL	测试条件 TEST CONDITION	最小值 MIN	典型值 TYP	最大值 MAX	单位 UNIT
栅极漏电流 Gate-body Leakage Current ( $V_{DS} = 0$ )	$I_{GSS}$	$V_{GS} = \pm 30V$			$\pm 100$	nA
漏-源导通电阻 Static Drain-source On Resistance	$R_{DS(ON)}$	$V_{GS} = 10V, I_D = 1.0A$ ③		3.3	3.7	$\Omega$
输入电容 Input Capacitance	$C_{iss}$	$V_{GS} = 0V, V_{DS} = 25V$ $F = 1.0MHz$		278		pF
输出电容 Output Capacitance	$C_{oss}$			30		
反向传输电容 Reverse transfer Capacitance	$C_{rss}$			5		
关断延迟 Turn -Off Delay Time	$T_d(off)$	$V_{DD} = 300V, I_D = 2.0A$ $R_G = 25\Omega$ ③		29		ns
栅极电荷 Total Gate Charge	$Q_g$	$I_D = 2.0A, V_{DS} = 480V$ $V_{GS} = 10V$ ③		7.4		nC
栅源电荷 Gate-to-Source Charge	$Q_{gs}$			1.4		nC
栅漏电荷 Gate-to-Drain Charge	$Q_{gd}$			2.2		nC
二极管正向电流 Continuous Diode Forward Current	$I_S$				2.0	A
二极管正向压降 Diode Forward Voltage	$V_{SD}$	$T_j = 25^\circ C, I_S = 2.0A$ $V_{GS} = 0V$ ③			1.4	V
反向恢复时间 Reverse Recovery Time	$t_{rr}$	$T_j = 25^\circ C, I_f = 2.0A$ $di/dt = 100A/\mu s$ ③		420		ns
反向恢复电荷 Reverse Recovery Charge	$Q_{rr}$			1.1		$\mu C$

●热特性

●Thermal Characteristics

参数 PARAMETER	符号 SYMBOL	最大值 MAX			单位 UNIT
		TO-220	TO-220FP	TO-262/263	
热阻结-壳 Thermal Resistance Junction-case	$R_{thJC}$	2.32	5.50	2.32	$^\circ C/W$
热阻结-环境 Thermal Resistance Junction-ambient	$R_{thJA}$	62.5	62.5	62.5	$^\circ C/W$

注释(Notes):

① 脉冲宽度: 以最高结温为限制

Repetitive rating: Pulse width limited by maximum junction temperature

② 初始结温= $25^\circ C$ ,  $V_{DD} = 50V$ ,  $L = 36mH$ ,  $R_G = 25\Omega$ ,  $I_{AS} = 2.0A$

Starting  $T_j = 25^\circ C$ ,  $V_{DD} = 50V$ ,  $L = 36mH$ ,  $R_G = 25\Omega$ ,  $I_{AS} = 2.0A$

③ 脉冲测试: 脉冲宽度 $\leq 300\mu s$ , 占空比 $\leq 2\%$

Pulse Test : Pulse width  $\leq 300\mu s$ , Duty cycle  $\leq 2\%$

N-沟道功率 MOS 管/ N-CHANNEL POWER MOSFET

SIF2N60FB

● 特性曲线



图 1 输出特性曲线, Tc=25°C

Fig1 Typical Output Characteristics, Tc=25°C

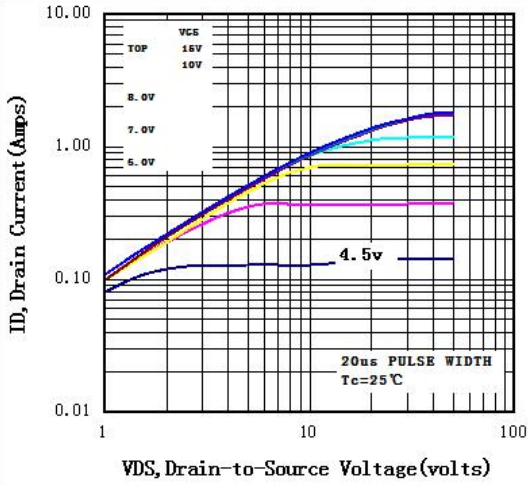

图 2 输出特性曲线, Tc=150°C

Fig2 Typical Output Characteristics, Tc=150°C

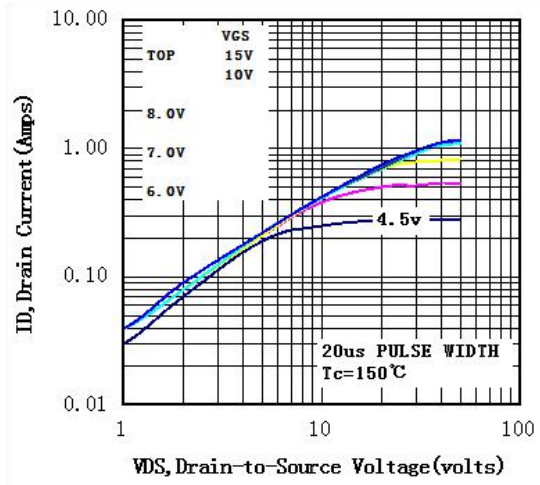

图 3 归一化导通电阻与温度曲线

Fig3 Normalized Resistance Vs. Temperature

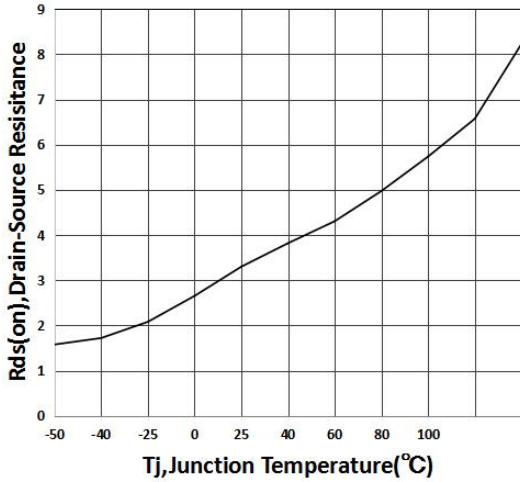

图 4 二极管正向压降曲线

Fig4 Typical Source-Drain Diode Forward Voltage

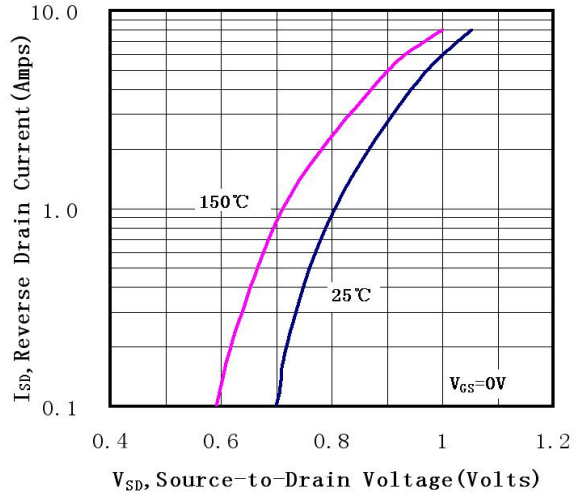

图 5 最大漏极电流与壳温曲线

Fig5 Maximum Drain Current Vs. Case Temperature

N-沟道功率 MOS 管 / N-CHANNEL POWER MOSFET

SIF2N60FB

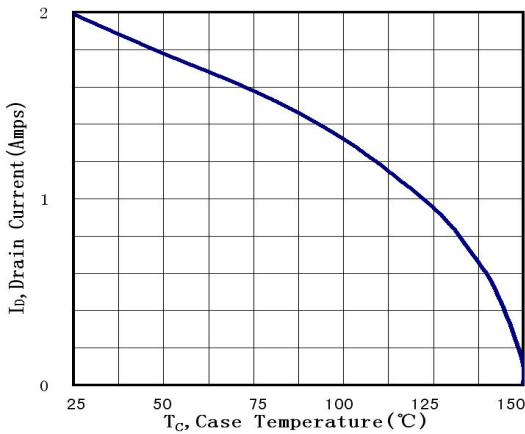
● 特性曲线



图 6-1 SIF2N60FB (TO-220FP)

最大安全工作区曲线

Fig6-1 Maximum Safe Operating Area

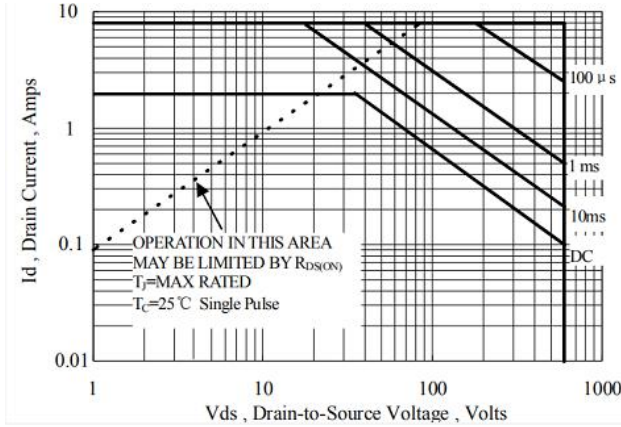

图 6-2 SIF2N60FB (TO-220/262/263)

最大安全工作区曲线

Fig6-2 Maximum Safe Operating Area

## TO-220 封装机械尺寸 TO-220 MECHANICAL DATA

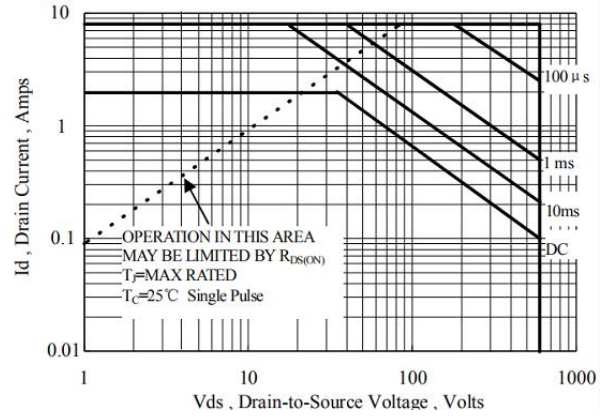
单位：毫米/UNIT: mm

符号 SYMBOL	最小值 min	典型值 nom	最大值 max	符号 SYMBOL	最小值 min	典型值 nom	最大值 max
A	4.00		4.80	E	9.90		10.70
B	1.20		1.50	e		2.54	
B1	1.00		1.40	F	1.10		1.45
b1	0.65		1.00	L	12.50		14.50
c	0.35		0.75	L1	3.00	3.50	4.00
D	15.00		16.50	Q	2.50		3.00
D1	5.90		6.90	Q1	2.00		3.00
				φP	3.60		3.90

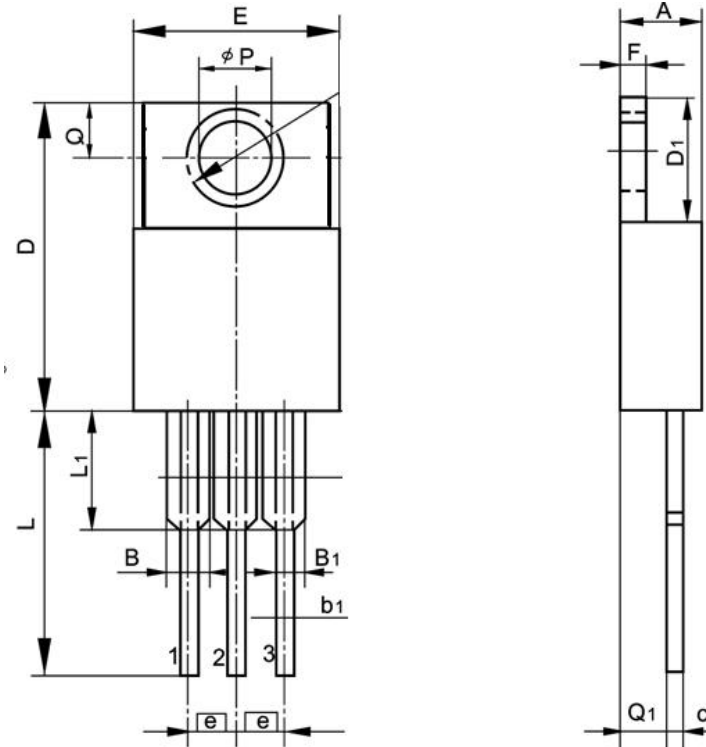

## TO-220FP 封装机械尺寸 TO-220FP MECHANICAL DATA

单位:毫米/UNIT: mm

符号 SYMBOL	最小值 min	典型值 nom	最大值 max	符号 SYMBOL	最小值 min	典型值 nom	最大值 max
A	4.40		4.95	e		2.54	
A <sub>1</sub>	2.30		2.90	L	12.50		14.30
b	0.45		0.90	L <sub>1</sub>	9.10		10.05
b <sub>1</sub>	1.10		1.70	L <sub>2</sub>	15.00		16.00
c	0.35		0.90	L <sub>3</sub>	3.00		4.00
D	14.50		17.00	øp	3.00		3.50
D <sub>1</sub>	6.10		9.00	Q	2.30		2.80
E	9.60		10.30				

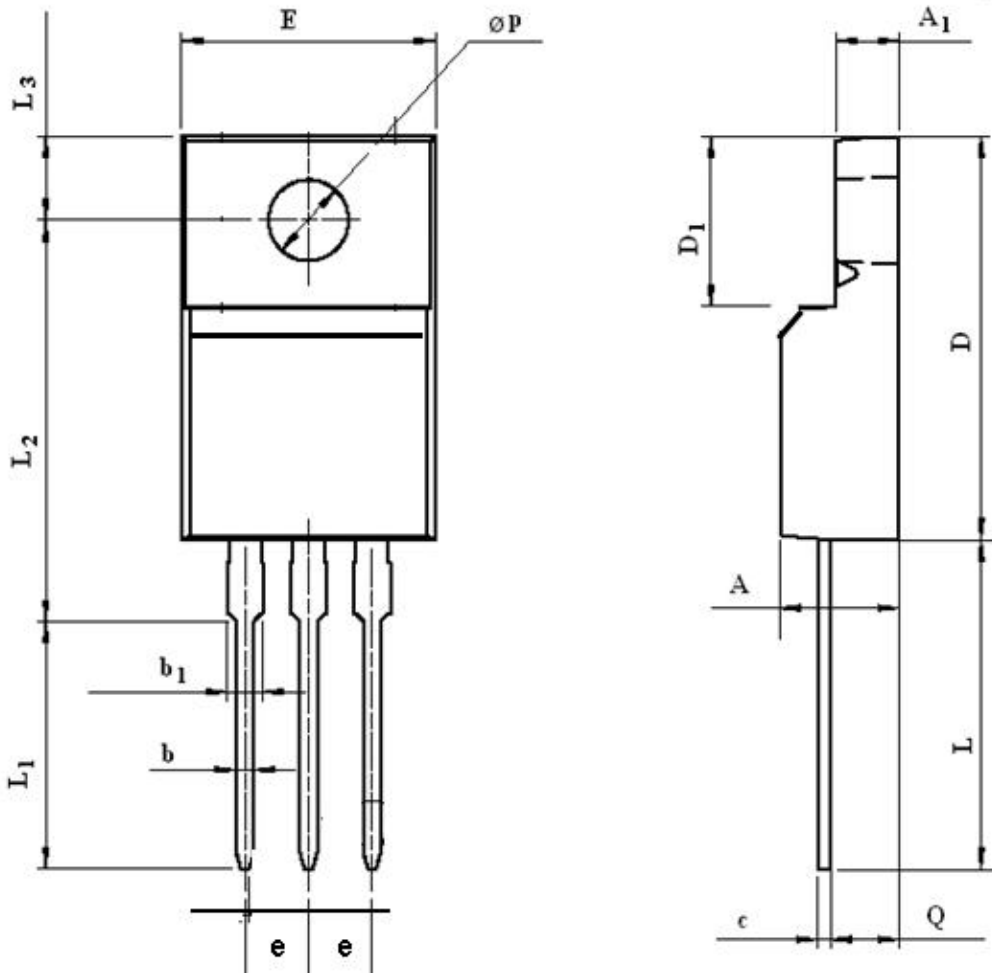

TO-262 封装机械尺寸  
TO-262 MECHANICAL DATA

单位: 毫米/UNIT: mm

符号 SYMBOL	最小值 min	典型值 nom	最大值 max	符号 SYMBOL	最小值 min	典型值 nom	最大值 max
A	3.80		4.80	e		2.54	
A1	2.00		2.80	e1			5.30
b	0.60		1.00	E	9.90		10.70
b1	1.20		1.40	L	12.50		14.50
c	0.40		0.70	L1	0.80	1.00	1.20
c2	1.10		1.40	L2			1.50
D			9.60				

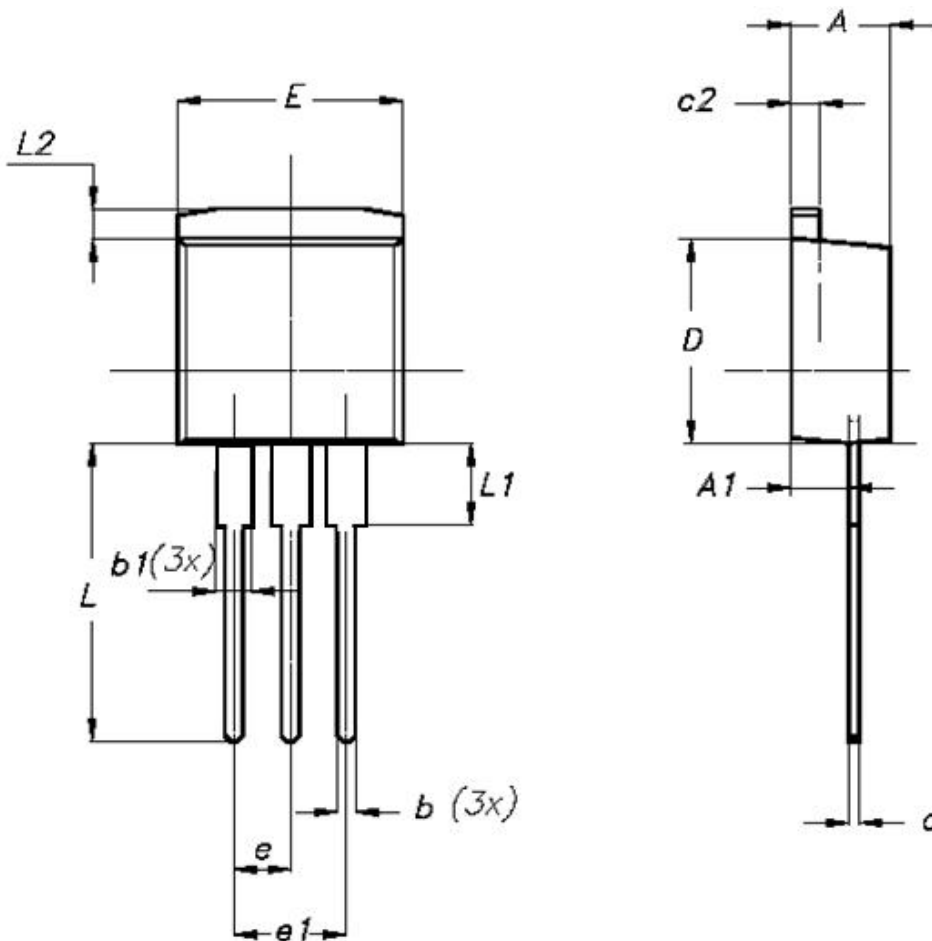



TO-263 封装机械尺寸

TO-263(D2PAK) MECHANICAL DATA

单位：毫米/UNIT: mm

符号 SYMBOL	最小值 min	典型值 nom	最大值 max	符号 SYMBOL	最小值 min	典型值 nom	最大值 max
A	4.42		4.72	E	8.99		9.29
B	1.22		1.32	e1	2.44		2.64
b	0.76		0.86	e2	4.98		5.18
b1	1.22		1.32	L1	15.19		15.79
b2	0.33		0.43	L2	2.29		2.79
C	1.22		1.32	L3	1.30		1.75
D	9.95		10.25				

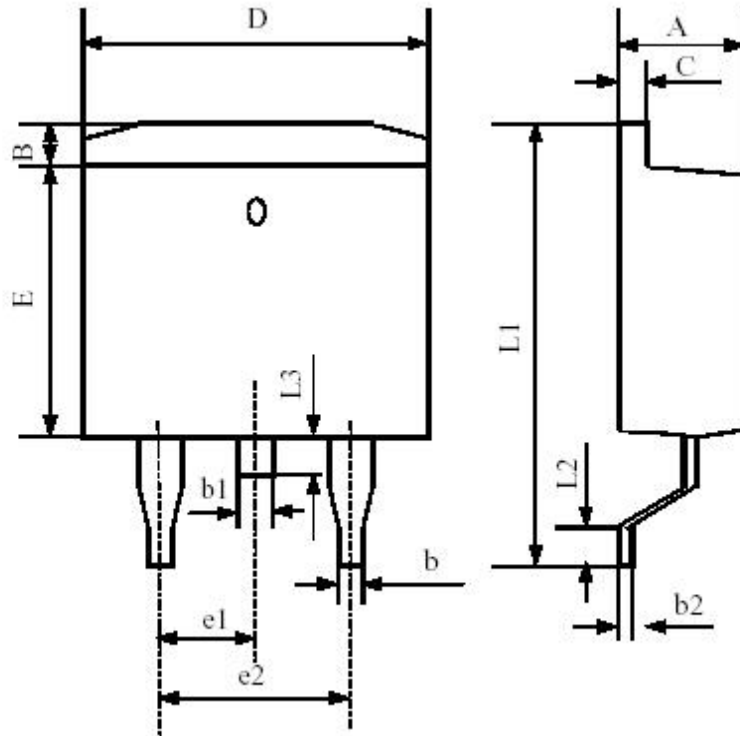



### TO-263 编带规格尺寸 TO-263 TAPE AND REEL DATA

单位:毫米/UNIT: mm

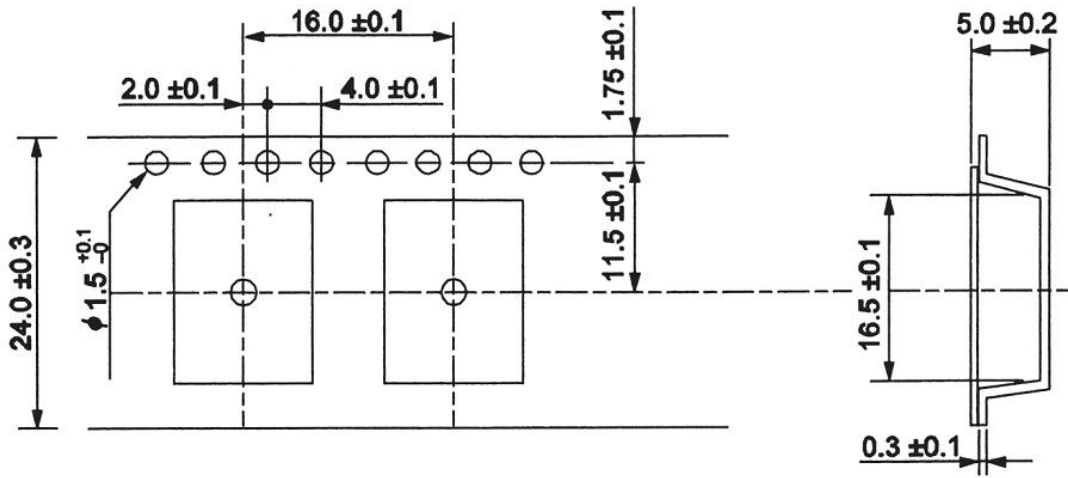

使用供带方向/USER DIRECTION OF FEED

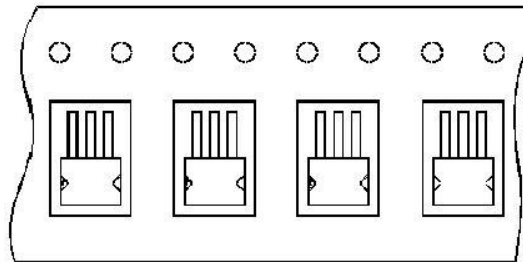

编带器件定位示意图/UNIT ORIENTATION