

N-沟道功率 MOS 管/ N-CHANNEL POWER MOSFET

SIF24N040

- 特点：热阻低 导通电阻低 栅极电荷低，开关速度快 输入阻抗高 符合RoHS规范
- FEATURES: ■LOW THERMAL RESISTANCE ■LOW $R_{DS(ON)}$ TO MINIMIZE CONDUCTIVE LOSS ■LOW GATE CHARGE FOR FAST SWITCHING ■HIGH INPUT RESISTANCE ■RoHS COMPLIANT
- 应用：低压高频逆变电路 同步整流 开关应用
- APPLICATION: ■LOW VOLTAGE,HIGH FREQUENCY INVERTERS ■SYNCHRONOUS RECTIFICATION ■SWITCH APPLICATIONS

●最大额定值 (TC=25°C)

●Absolute Maximum Ratings (Tc=25°C) **SOP8**

参数 PARAMETER	符号 SYMBOL	额定值 VALUE	单位 UNIT
漏-源电压 Drain-source Voltage	V_{DS}	40	V
栅-源电压 gate-source Voltage	V_{GS}	±20	V
漏极电流 Continuous Drain Current TC=25°C	I_D	24	A
耗散功率 Total Power Dissipation	P_{tot}	3.6	W
最高结温 Junction Temperature	T_j	150	°C
存储温度 Storage Temperature	T_{STG}	-55-175	°C
单脉冲雪崩能量 Single Pulse Avalanche Energy ①	E_{AS}	380	mJ

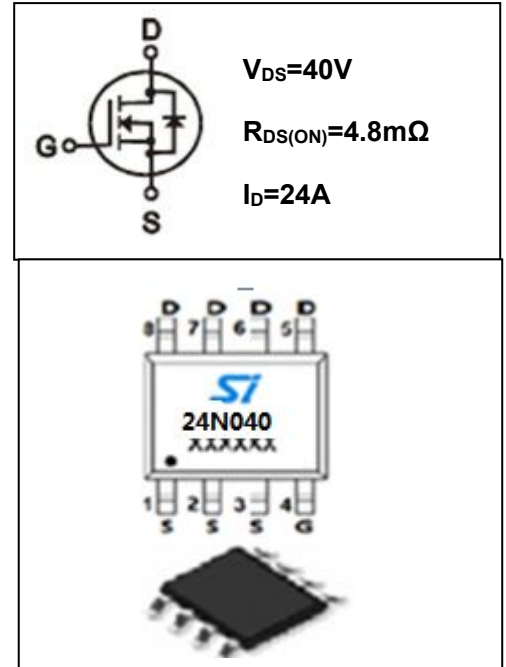

●电特性 (Tc=25°C)

●Electronic Characteristics (Tc=25°C)

参数 PARAMETER	符号 SYMBOL	测试条件 TEST CONDITION	最小值 MIN	典型值 TYP	最大值 MAX	单位 UNIT
漏-源击穿电压 Drain-source Breakdown Voltage	BV_{DSS}	$V_{GS}=0V, I_D=250\mu A$	40			V
栅极开启电压 Gate Threshold Voltage	$V_{GS(TH)}$	$V_{GS}=V_{DS}, I_D=250\mu A$ ②	1.0	1.8	2.5	V
漏-源漏电流 Drain-source Leakage Current	I_{DSS}	$V_{DS}=40V, V_{GS}=0V$			1	μA
栅极漏电流 Gate-body Leakage Current ($V_{DS}=0$)	I_{GSS}	$V_{GS}=\pm 20V$			±100	nA
漏-源导通电阻 Static Drain-source On Resistance	$R_{DS(ON)}$	$V_{GS}=10V, I_D=20A$ ②		4.8	6.0	mΩ
		$V_{GS}=4.5V, I_D=10A$ ②		6.5	8.0	
跨导 Forwad Transconductance	g_{FS}	$V_{DS}=10V, I_D=10A$ ②	10			S

●订单信息/ORDERING INFORMATION:

包装形式/PACKING	订货编码/ORDERING CODE	
	普通塑封料/ Normal Package Material	无卤塑封料/Halogen Free
SOP8 条管装/TUBE PACKING	SIF24N040 SOP8-TU	SIF24N040 SOP8-TU-HF
SOP8 编带装/TAPE & REEL PACKING	SIF24N040 SOP8-TR	SIF24N040 SOP8-TR-HF

N-沟道功率 MOS 管/ N-CHANNEL POWER MOSFET

SIF24N040

参数 PARAMETER	符号 SYMBOL	测试条件 TEST CONDITION	最小值 MIN	典型值 TYP	最大值 MAX	单位 UNIT
输入电容 Input Capacitance	Ciss	$V_{GS} = 0V, V_{DS} = 25V$ $F = 1.0MHz$		4800		pF
输出电容 Output Capacitance	Coss			450		
反向传输电容 Reverse Transfer Capacitance	Crss			380		
导通延迟 Turn -On Delay Time	Td(on)	$V_{DD}=20V, I_D = 2A,$ $V_{GS} = 10V, R_G=3\Omega$		15		ns
开启上升时间 Turn -On Rise Time	T_r			18		
关断延迟 Turn -Off Delay Time	Td(off)			52		
关断下降时间 Turn -Off Fall Time	T_f			23		
栅极电荷 Total Gate Charge	Qg	$I_D = 20A, V_{DS} = 20V$ $V_{GS} = 10V$		75		nC
栅源电荷 Gate-to-Source Charge	Qgs			10.5		nC
栅漏电荷 Gate-to-Drain Charge	Qgd			17		nC
二极管正向压降 Diode Forward Voltage	V_{SD}	$T_j=25^\circ C, I_s=10A$ $V_{GS}=0V$		0.8	1.2	V
反向恢复时间 Reverse Recovery Time	trr	$T_j=25^\circ C, I_s=10A$ $di/dt=100A/\mu s$		42		ns
反向恢复电荷 Reverse Recovery Charge	Qrr			45		nC

●热特性

●Thermal Characteristics

参数 PARAMETER	符号 SYMBOL	最小值 MIN	典型值 TYP	最大值 MAX	单位 UNIT
热阻结-壳 Thermal Resistance Junction-case	RthJC			34.7	$^\circ C/W$

注释(Notes):

- ① 初始结温=25°C, L=0.1mH。
Starting $T_j=25^\circ C, L=0.1mH$ 。
- ② 脉冲测试: 脉冲宽度 $\leq 300\mu s$, 占空比 $\leq 2\%$
Pulse Test : Pulse width $\leq 300\mu s$, Duty cycle $\leq 2\%$

N-沟道功率 MOS 管/ N-CHANNEL POWER MOSFET

SIF24N040

● 特性曲线



图 1 输出特性曲线

Fig.1 Output Characteristics

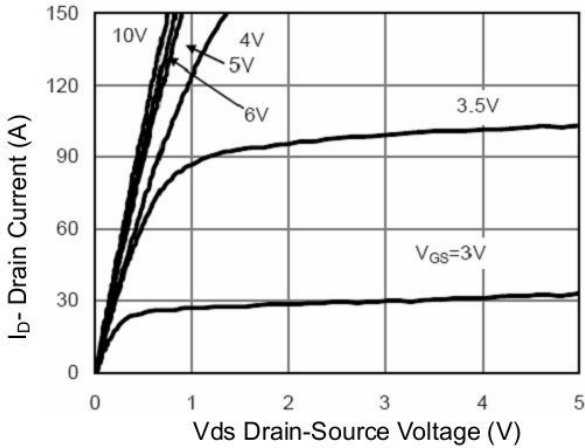

图 2 归一化导通电阻与结温关系曲线

Fig.2 Normalized RDSON vs. T_J

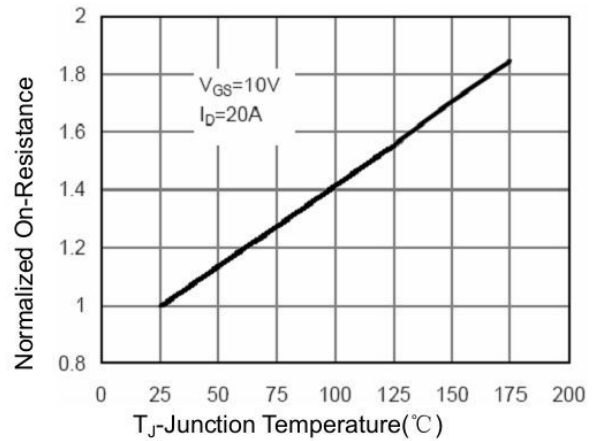

图 3 归一化开启电压与结温关系曲线

Fig.3 Normalized V_{th} vs. T_J

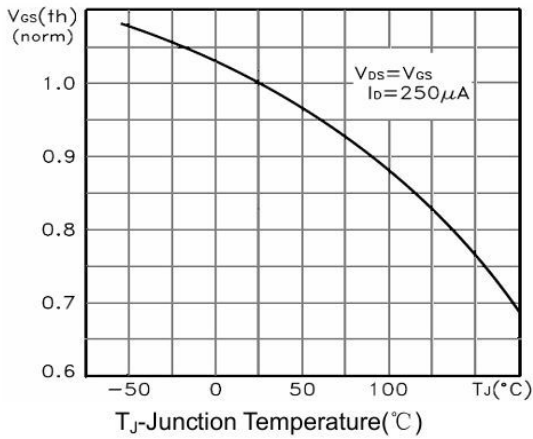

图 4 栅电荷波形

Fig.4 Gate Charge Waveform

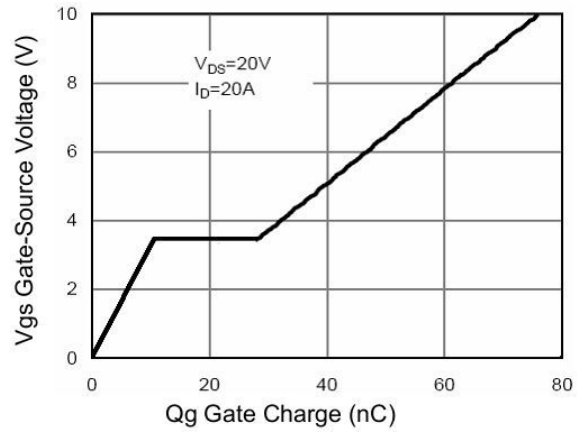

图 5 电容曲线

Fig.5 Capacitance

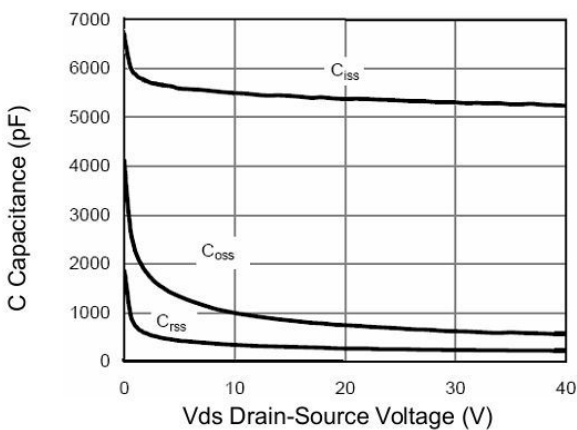

图 6.二极管正向曲线

Fig.6 Source Drain Diode Forward

SOP8 封装机械尺寸 SOP8 MECHANICAL DATA

单位:毫米/UNIT: mm

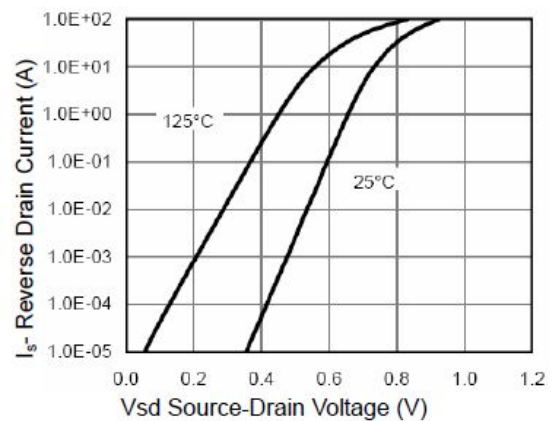
符号 SYMBOL	最小值 min	典型值 nom	最大值 max	符号 SYMBOL	最小值 min	典型值 nom	最大值 max
A	4.80		5.00	C	1.30		1.50
A1	0.37		0.47	C1	0.55		0.75
A2		1.27 TYP		C2	0.55		0.65
A3		0.41 TYP		C3	0.05		0.20
B	5.80		6.20	C4	0.19	0.20TYP	0.23
B1	3.80		4.00	D		1.05TYP	
B2		5.0TYP		D1	0.40		0.62

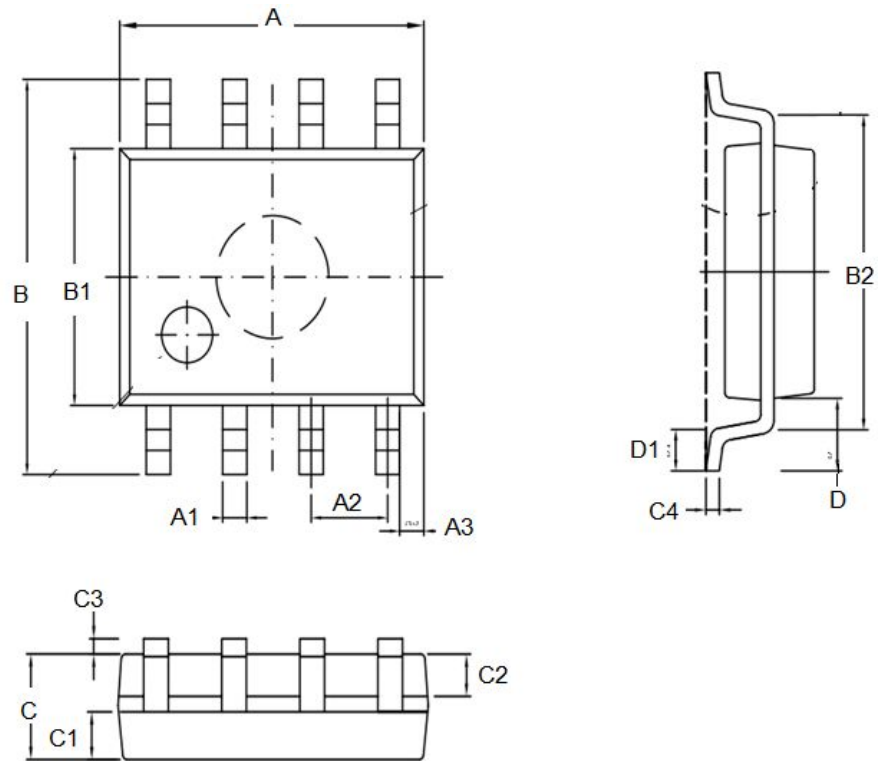

SOP8 (13")编带规格 SOP8 (13")TAPE AND REEL DATA

单位:毫米/UNIT: mm

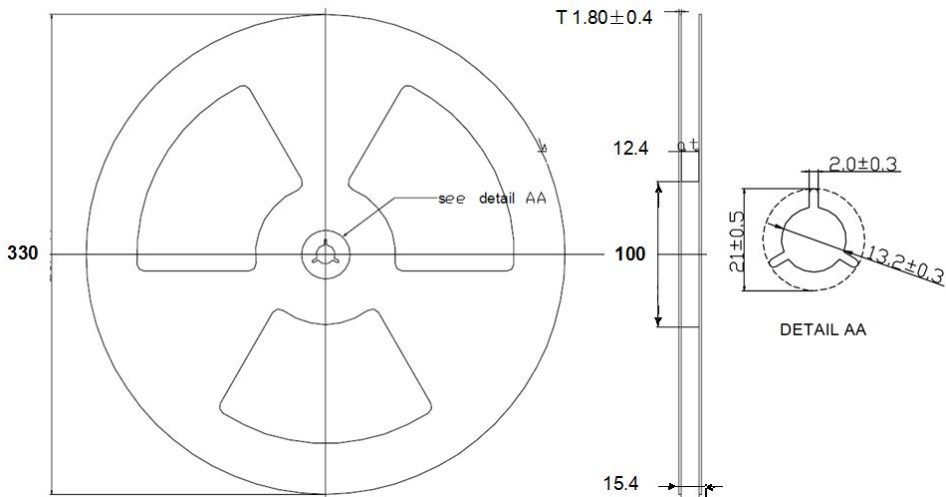
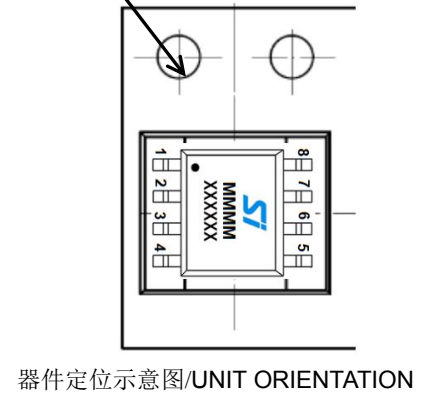
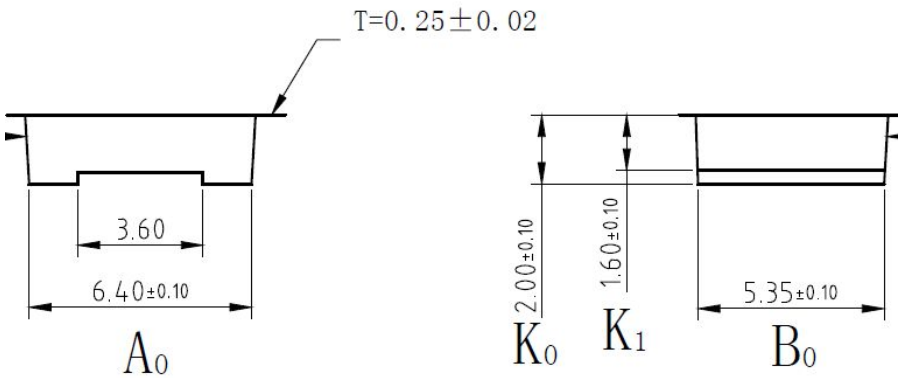
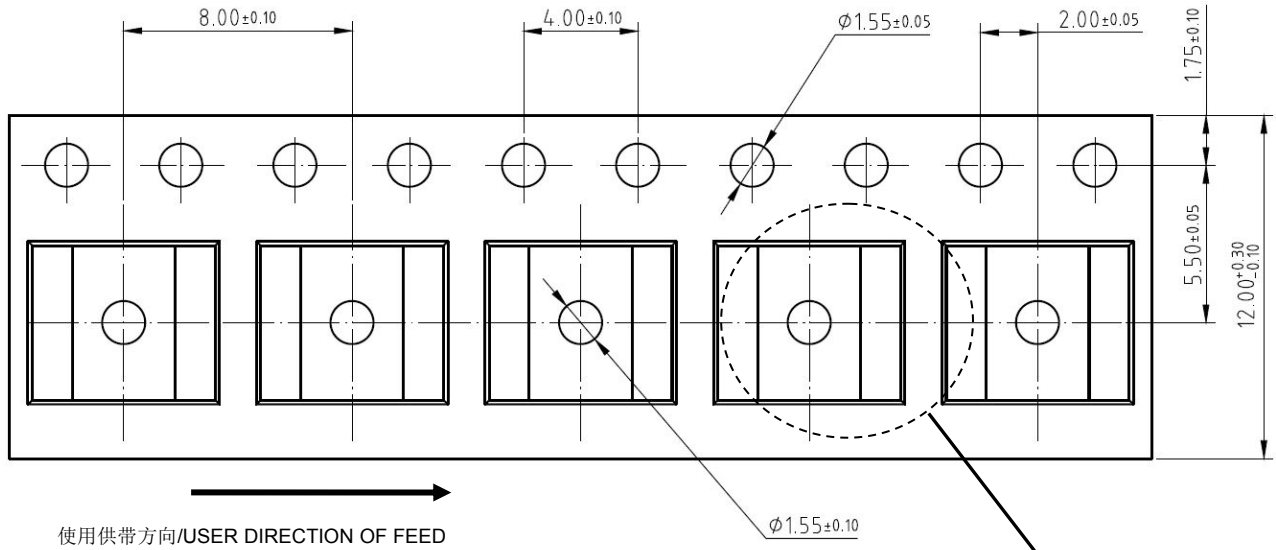

13"卷盘/REEL