

**N-沟道功率 MOS 管/ N-CHANNEL POWER MOSFET**

**SIF11N060**

- 特点：热阻低 导通电阻低 栅极电荷低，开关速度快 输入阻抗高 符合RoHS规范
- FEATURES: ■LOW THERMAL RESISTANCE ■LOW  $R_{DS(ON)}$  TO MINIMIZE CONDUCTIVE LOSS ■LOW GATE CHARGE FOR FAST SWITCHING ■HIGH INPUT RESISTANCE ■RoHS COMPLIANT
- 应用：低压高频逆变电路 同步整流 开关
- APPLICATION: ■LOW VOLTAGE,HIGH FREQUENCY INVERTERS ■SYNCHRONOUS RECTIFIER ■PRIMARY SWITCH

●最大额定值 (TC=25°C)

●Absolute Maximum Ratings (Tc=25°C) SOP-8

参数 PARAMETER	符号 SYMBOL	额定值 VALUE	单位 UNIT
漏-源电压 Drain-source Voltage	$V_{DS}$	60	V
栅-源电压 gate-source Voltage	$V_{GS}$	±20	V
漏极电流 Continuous Drain Current TC=25°C ①	$I_D$	11*	A
耗散功率 Total Power Dissipation ①	$P_{tot}$	2.5*	W
最高结温 Junction Temperature	$T_j$	150	°C
存储温度 Storage Temperature	$T_{STG}$	-55-175	°C
单脉冲雪崩能量 Single Pulse Avalanche Energy ②	$E_{AS}$	95	mJ

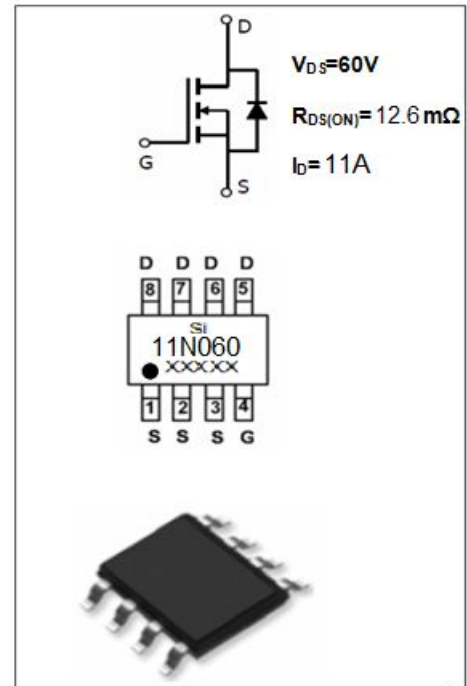

●电特性 (Tc=25°C)

●Electronic Characteristics (Tc=25°C)

参数 PARAMETER	符号 SYMBOL	测试条件 TEST CONDITION	最小值 MIN	典型值 TYP	最大值 MAX	单位 UNIT
漏-源击穿电压 Drain-source Breakdown Voltage	$BV_{DSS}$	$V_{GS}=0V, I_D=250\mu A$	60			V
栅极开启电压 Gate Threshold Voltage	$V_{GS(TH)}$	$V_{GS}=V_{DS}, I_D=250\mu A$	1.0		3.0	V
漏-源漏电流 Drain-source Leakage Current	$I_{DSS}$	$V_{DS}=60V, V_{GS}=0V, T_j=25^\circ C$			1	$\mu A$
		$V_{DS}=60V, V_{GS}=0V, T_j=125^\circ C$			10	$\mu A$
栅极漏电流 Gate-body Leakage Current	$I_{GSS}$	$V_{GS}=\pm 20V, V_{DS}=0V$			±100	nA
漏-源导通电阻 Static Drain-source On Resistance	$R_{DS(ON)}$	$V_{GS}=10V, I_D=9A$		12.6	15	mΩ
		$V_{GS}=4.5V, I_D=6A$		15.5	18	
跨导 Forwad Transconductance	$g_{FS}$	$V_{DS}=5V, I_D=9A$		19		S

●订单信息/ORDERING INFORMATION:

包装形式/PACKING	订货编码/ORDERING CODE	
	普通塑封料/ Normal Package Material	无卤塑封料/Halogen Free
SOP-8 条管装/TUBE PACKING	SIF11N060 SOP-8-TU	SIF11N060 SOP-8-TU-HF
SOP-8 编带装/TAPE & REEL PACKING	SIF11N060 SOP-8-TR	SIF11N060 SOP-8-TR-HF

N-沟道功率 MOS 管/ N-CHANNEL POWER MOSFET

SIF11N060

参数 PARAMETER	符号 SYMBOL	测试条件 TEST CONDITION	最小值 MIN	典型值 TYP	最大值 MAX	单位 UNIT
输入电容 Input Capacitance	Ciss	$V_{GS} = 0V, V_{DS} = 25V$ $F = 1.0MHz$		2489		pF
输出电容 Output Capacitance	Coss			276		
反向传输电容 Reverse Transfer Capacitance	Crss			130		
栅极电荷 Total Gate Charge	Qg	$I_D = 9A, V_{DS} = 20V$ $V_{GS} = 10V$		54.9		nC
栅源电荷 Gate-to-Source Charge	Qgs			8		nC
栅漏电荷 Gate-to-Drain Charge	Qgd			14.5		nC
栅极开启电荷量 Gate Charge At Threshold	Qg(th)			3.6		nC
导通延迟 Turn -On Delay Time	Td(on)	$V_{DD}=30V, R_L=1\Omega$ $V_{GS} = 10V, R_{GEN}=3\Omega$		8.5		ns
开启上升时间 Turn -On Rise Time	T <sub>r</sub>			6		ns
关断延迟 Turn -Off Delay Time	Td(off)			30		ns
关断下降时间 Turn -Off Fall Time	T <sub>f</sub>			5		ns
二极管正向压降 Diode Forward Voltage	V <sub>SD</sub>	$T_j=25^\circ C, I_F=9A$ $V_{GS} = 0V$ ③			1.2	V
反向恢复时间 Reverse Recovery Time	t <sub>rr</sub>	$I_f=9A, di/dt=100A/\mu s$ $T_j=25^\circ C$ ③		30		ns
反向恢复电荷 Reverse Recovery Charge	Q <sub>rr</sub>			44		nC

●热特性

●Thermal Characteristics

参数 PARAMETER	符号 SYMBOL	最大值 MAX	单位 UNIT
热阻结-壳 Thermal Resistance Junction-case	R <sub>thJC</sub>	50	°C/W
热阻结-壳 Thermal Resistance Junction-Ambient	R <sub>thJA</sub>	75	°C/W

注释(Notes):

- ① 以最高结温为限制， T<sub>c</sub>=25°C时测试。  
I<sub>D</sub> & P<sub>D</sub> base on maximum allowable junction temperature, test at T<sub>c</sub>=25°C.
- ② 初始结温=25°C, L=0.1mH.  
Starting T<sub>j</sub>=25°C, L=0.1mH
- ③ 脉冲测试: 脉冲宽度≤ 300μs , 占空比≤ 2%  
Pulse Test : Pulse width ≤ 300μs, Duty cycle ≤ 2%

N-沟道功率 MOS 管/ N-CHANNEL POWER MOSFET

SIF11N060

● 特性曲线

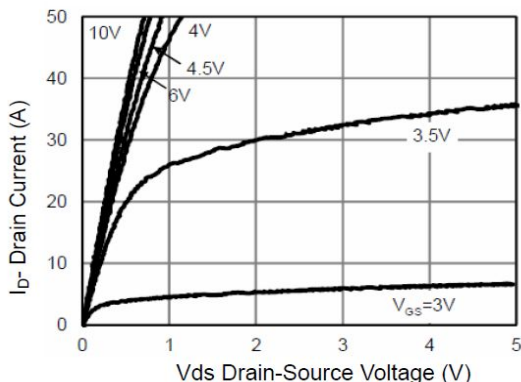

Figure 1 Output Characteristics

图 1 输出特性曲线,  $T_c=25^\circ\text{C}$

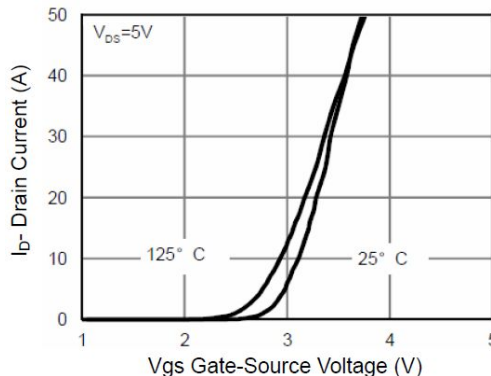

Figure 2 Transfer Characteristics

图 2 转移特性曲线

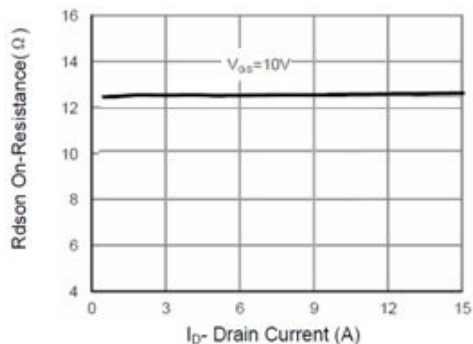

Figure 3 Rdson- Drain Current

图 3 导通电阻与漏极电流 曲线

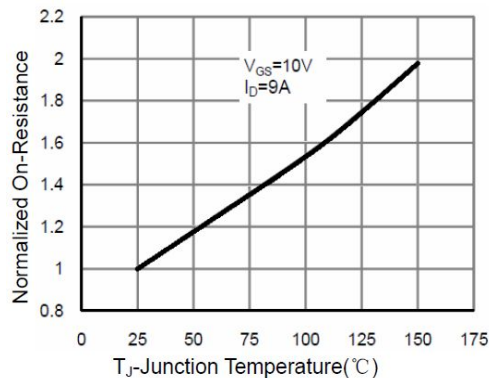

Figure 4 Rdson-Junction Temperature

图 4 导通电阻与结温度 曲线

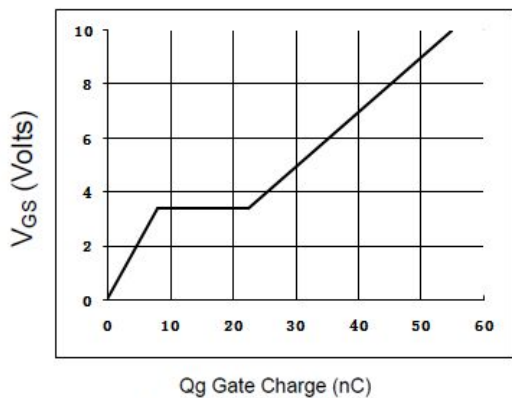

Figure 5 Gate Charge

图 5 栅电荷 曲线

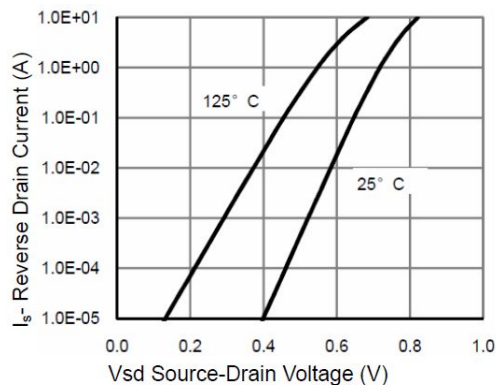

Figure 6 Source- Drain Diode Forward

图 6.二极管正向压降与源极电流 曲线

N-沟道功率 MOS 管/ N-CHANNEL POWER MOSFET

SIF11N060

● 特性曲线

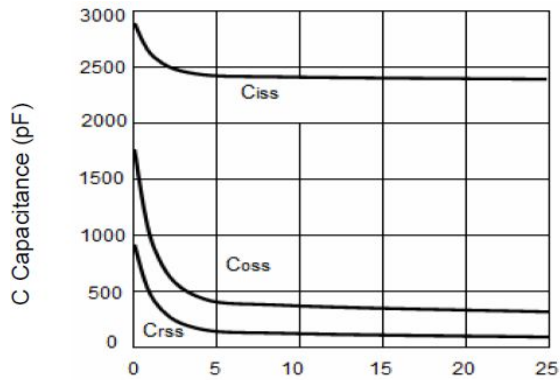

V<sub>DS</sub> Drain-Source Voltage (V)  
Figure 7. Capacitance vs Vds

图 7 电容特性曲线

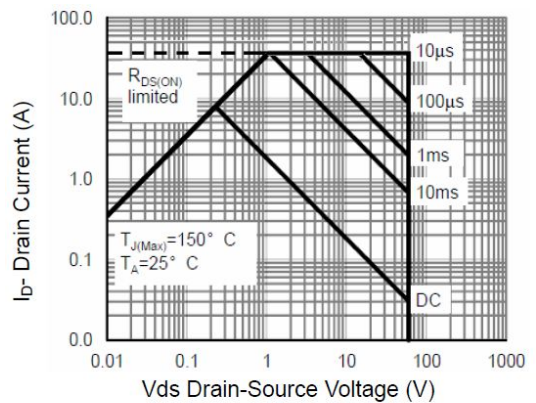

Figure 8 Safe Operation Area

图 8 SOA 曲线

## SOP8 封装机械尺寸 SOP8 MECHANICAL DATA

单位:毫米/UNIT: mm

符号 SYMBOL	最小值 min	典型值 nom	最大值 max	符号 SYMBOL	最小值 min	典型值 nom	最大值 max
A	4.80		5.10	C	1.30		1.50
A1	0.37		0.47	C1	0.55		0.75
A2		1.27 TYP		C2	0.55		0.65
A3		0.41 TYP		C3	0.05		0.20
B	5.80		6.20	C4	0.19	0.20TYP	0.23
B1	3.80		4.00	D		1.05TYP	
B2		5.0TYP		D1	0.40		0.62

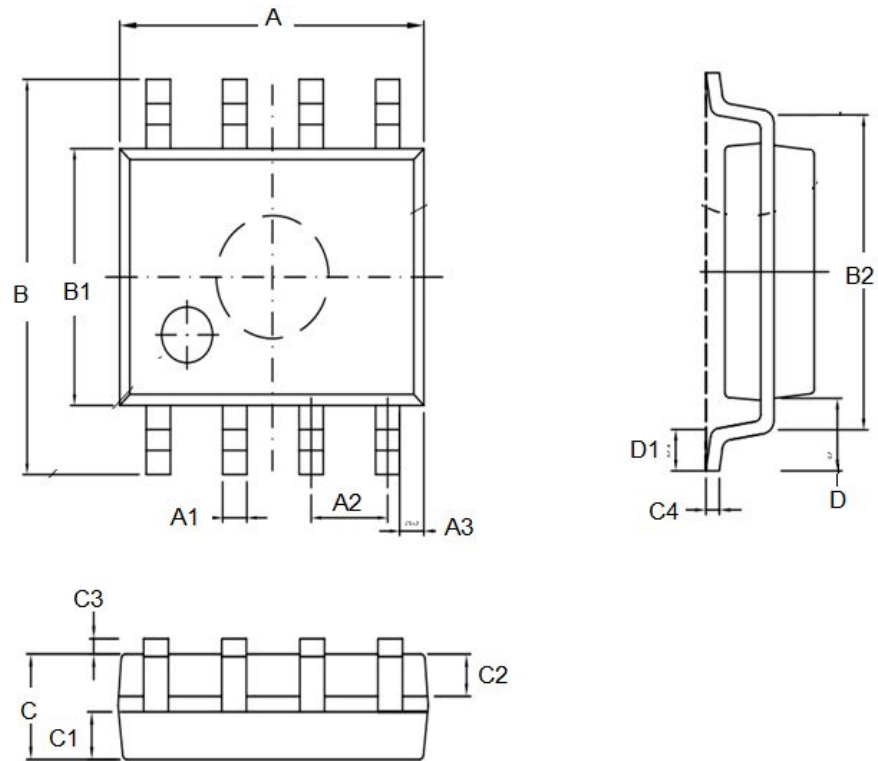

## SOP8 (13")编带规格 SOP8 (13")TAPE AND REEL DATA

单位:毫米/UNIT: mm

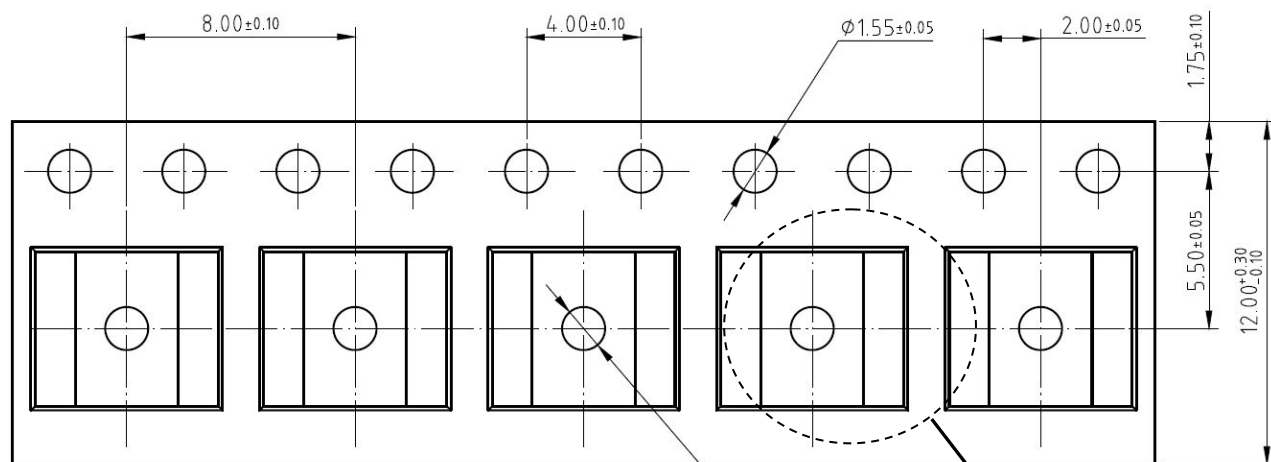

使用供带方向/USER DIRECTION OF FEED

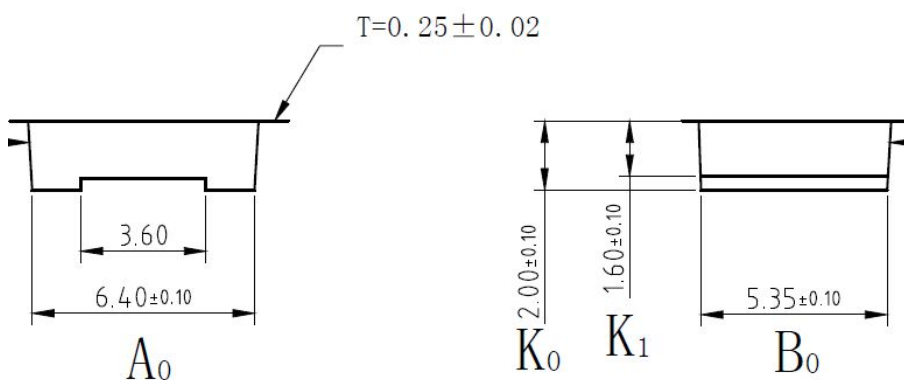

器件定位示意图/UNIT ORIENTATION

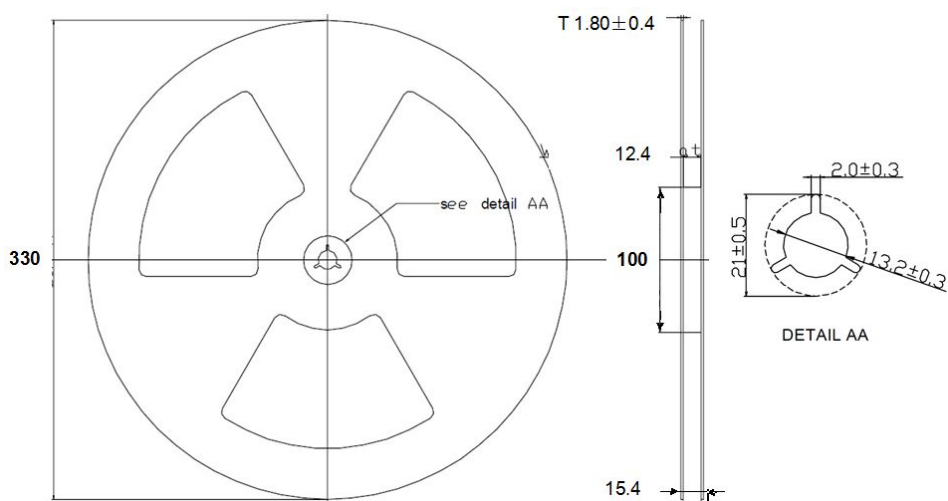

13"卷盘/REEL