

N-沟道功率 MOS 管/ N-CHANNEL POWER MOSFET

SIF100N030B

- 特点：热阻低 导通电阻低 栅极电荷低，开关速度快 输入阻抗高 符合RoHS规范
- FEATURES: ■LOW THERMAL RESISTANCE ■LOW $R_{DS(ON)}$ TO MINIMIZE CONDUCTIVE LOSS ■LOW GATE CHARGE FOR FAST SWITCHING ■HIGH INPUT RESISTANCE ■RoHS COMPLIANT
- 应用：低压高频逆变电路 同步整流 开关应用
- APPLICATION: ■LOW VOLTAGE,HIGH FREQUENCY INVERTERS ■SYNCHRONOUS RECTIFICATION ■SWITCH APPLICATIONS

●最大额定值 (TC=25°C)

●Absolute Maximum Ratings (Tc=25°C) TO-251T/251S/252/252T

参数 PARAMETER	符号 SYMBOL	额定值 VALUE	单位 UNIT
漏-源电压 Drain-source Voltage	V_{DS}	30	V
栅-源电压 gate-source Voltage	V_{GS}	± 20	V
漏极电流 Continuous Drain Current TC=25°C	I_D	100	A
耗散功率 Total Power Dissipation	P_{tot}	75	W
最高结温 Junction Temperature	T_j	150	°C
存储温度 Storage Temperature	T_{STG}	-55-175	°C
单脉冲雪崩能量 Single Pulse Avalanche Energy ①	E_{AS}	210	mJ

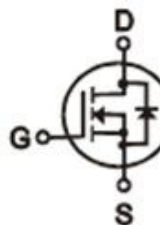

$V_{DS}=30V$

$R_{DS(ON)}=3.2m\Omega$

$I_D=100A$



TO-251T(IPAK)

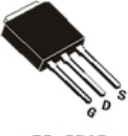

TO-251S

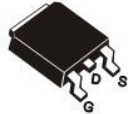

TO-252(DPAK)

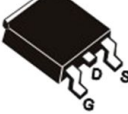

TO-252T

●电特性 (Tc=25°C)

●Electronic Characteristics (Tc=25°C)

参数 PARAMETER	符号 SYMBOL	测试条件 TEST CONDITION	最小值 MIN	典型值 TYP	最大值 MAX	单位 UNIT
漏-源击穿电压 Drain-source Breakdown Voltage	BV_{DSS}	$V_{GS}=0V, I_D=250\mu A$	30			V
栅极开启电压 Gate Threshold Voltage	$V_{GS(TH)}$	$V_{GS}=V_{DS}, I_D=250\mu A$	1.0	1.3	2.5	V
漏-源漏电流 Drain-source Leakage Current	I_{DSS}	$V_{DS}=30V, V_{GS}=0V$			1	μA
栅极漏电流 Gate-body Leakage Current ($V_{DS}=0$)	I_{GSS}	$V_{GS}=\pm 20V$			± 100	nA
漏-源导通电阻 Static Drain-source On Resistance	$R_{DS(ON)}$	$V_{GS}=10V, I_D=24A$		3.2	4.5	m Ω
		$V_{GS}=4.5V, I_D=12A$		3.8	5.0	
跨导 Forward Transconductance	g_{FS}	$V_{DS}=10V, I_D=10A$		15		S

●订单信息/ORDERING INFORMATION:

包装形式/PACKING	订货编码/ORDERING CODE	
	普通塑封料 Normal Package Material	无卤塑封料 Halogen Free
TO-252(T)&251T(S)条管装 TUBE PACKING	SIF100N030B TO-251-TU 或 TO-251S-TU 或 TO-252(T)-TU	SIF100N030B TO-251-TU-HF 或 TO-251S-TU-HF 或 TO-252(T)-TU-HF
TO-252(T) 编带装/TAPE & REEL PACKING	SIF100N030B TO-252(T)-TR	SIF100N030B TO-252(T)-TR-HF

N-沟道功率 MOS 管/ N-CHANNEL POWER MOSFET

SIF100N030B

参数 PARAMETER	符号 SYMBOL	测试条件 TEST CONDITION	最小值 MIN	典型值 TYP	最大值 MAX	单位 UNIT
输入电容 Input Capacitance	Ciss	$V_{GS} = 0V, V_{DS} = 25V$ $F = 1.0MHz$		3650		pF
输出电容 Output Capacitance	Coss			396		
反向传输电容 Reverse Transfer Capacitance	Crss			320		
导通延迟 Turn -On Delay Time	Td(on)	$V_{DD}=15V, I_D = 15A,$ $V_{GS} = 10V, R_G=3\Omega$		12.6		ns
开启上升时间 Turn -On Rise Time	T_r			19.5		
关断延迟 Turn -Off Delay Time	Td(off)			42.8		
关断下降时间 Turn -Off Fall Time	T_f			13.2		
栅极电荷 Total Gate Charge	Qg	$I_D = 20A, V_{DS} = 20V$ $V_{GS} = 10V$		68		nC
栅源电荷 Gate-to-Source Charge	Qgs			10		nC
栅漏电荷 Gate-to-Drain Charge	Qgd			18		nC
二极管正向压降 Diode Forward Voltage	V_{SD}	$T_j=25^\circ C, I_s=10A$ $V_{GS}=0V$		0.8	1.3	V
反向恢复时间 Reverse Recovery Time	trr	$T_j=25^\circ C, I_s=1A$ $di/dt=100A/\mu s$		21		ns
反向恢复电荷 Reverse Recovery Charge	Qrr			58		nC

●热特性

●Thermal Characteristics

参数 PARAMETER	符号 SYMBOL	最小值 MIN	典型值 TYP	最大值 MAX	单位 UNIT
热阻结-壳 Thermal Resistance Junction-case	RthJC			1.67	$^\circ C/W$
热阻结-壳 Thermal Resistance Junction-ambient	RthJA			62.5	$^\circ C/W$

注释(Notes):

- ① 初始结温=25 $^\circ C$, L=0.1mH。
Starting $T_j=25^\circ C, L=0.1mH$ 。

N-沟道功率 MOS 管/ N-CHANNEL POWER MOSFET

SIF100N030B

● 特性曲线



图 1 输出特性曲线

Fig.1 output characteristics

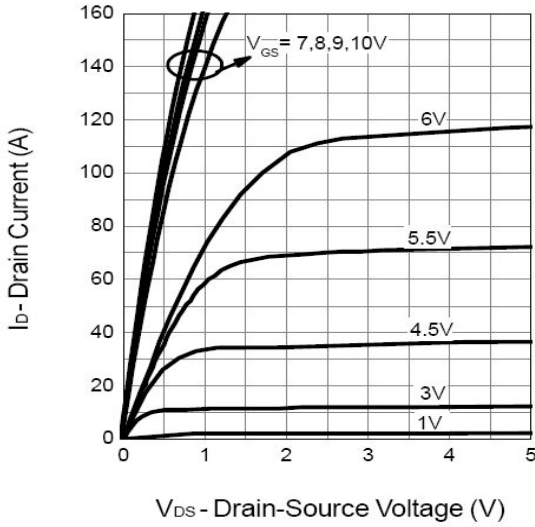

图 2 归一化导通电阻与结温关系曲线

Fig.2 Normalized RDSON vs. T_J

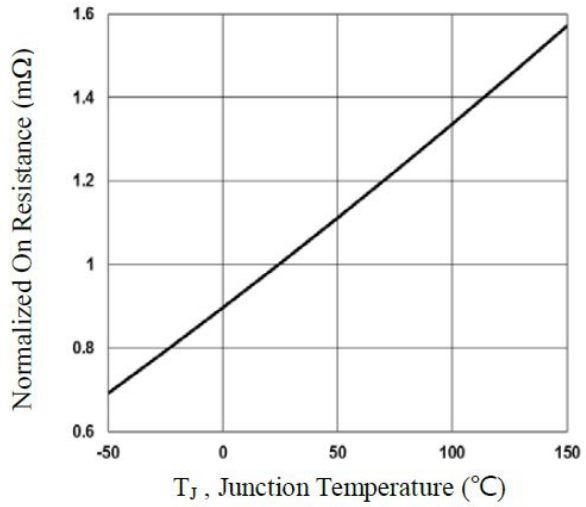

图 3 归一化开启电压与结温关系曲线

Fig.3 Normalized V_{th} vs. T_J

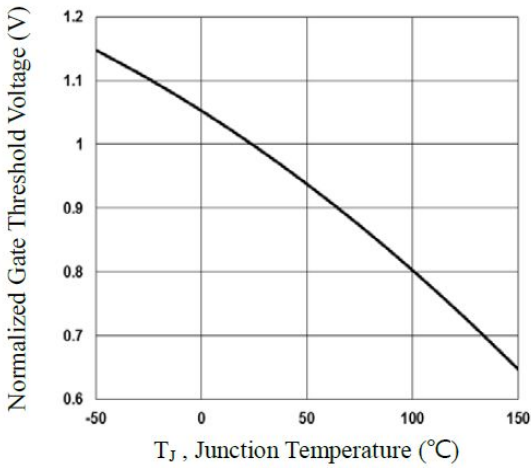

图 4 栅电荷波形

Fig.4 Gate Charge Waveform

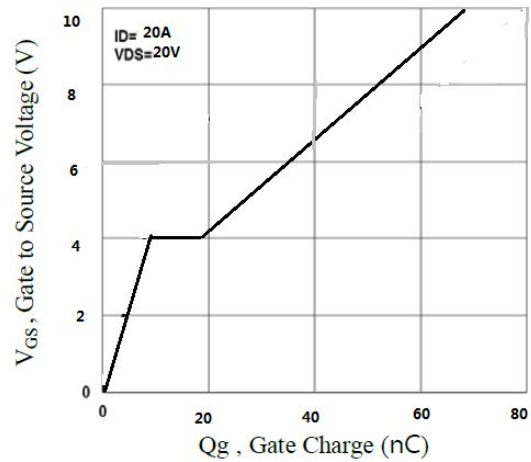

图 5 归一化阻抗

Fig.5 Normalized Transient Impedance

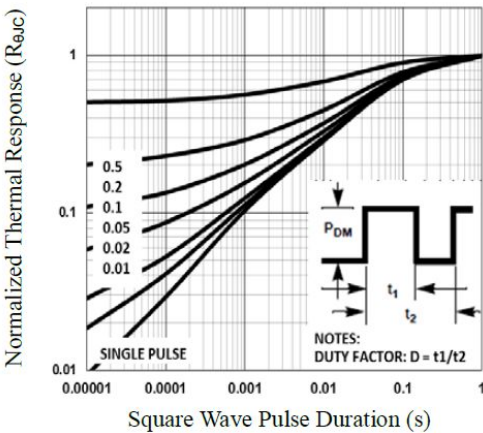

图 6.最大安全工作区

Fig.6 Maximum Safe Operation Area

TO-251T 封装机械尺寸 TO-251T (IPAK) MECHANICAL DATA

单位:毫米/UNIT: mm

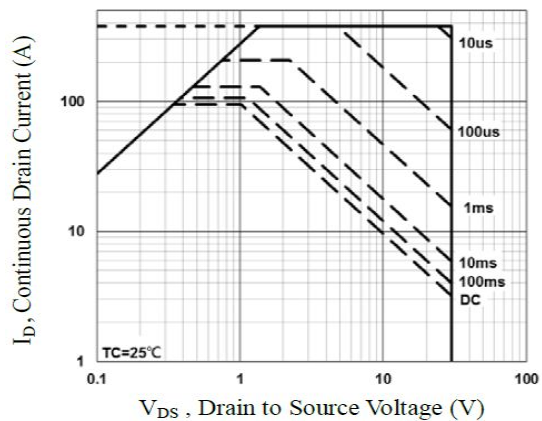
符号/SYMBOL	最小值/min	典型值/nom	最大值/max
A	2.10		2.50
A ₁	0.95		1.30
B	0.80		1.25
b	0.50		0.80
b ₁	0.70		0.80
c	0.45		0.70
c ₁	0.45		0.70
D	6.35		6.80
D ₁	5.10		5.50
E	5.30		6.30
e	2.25	2.30	2.35
L	7.00		9.20
H	0.35		0.45
W ₁	0.30		0.50
W ₂	0.20		0.40

[S/L]

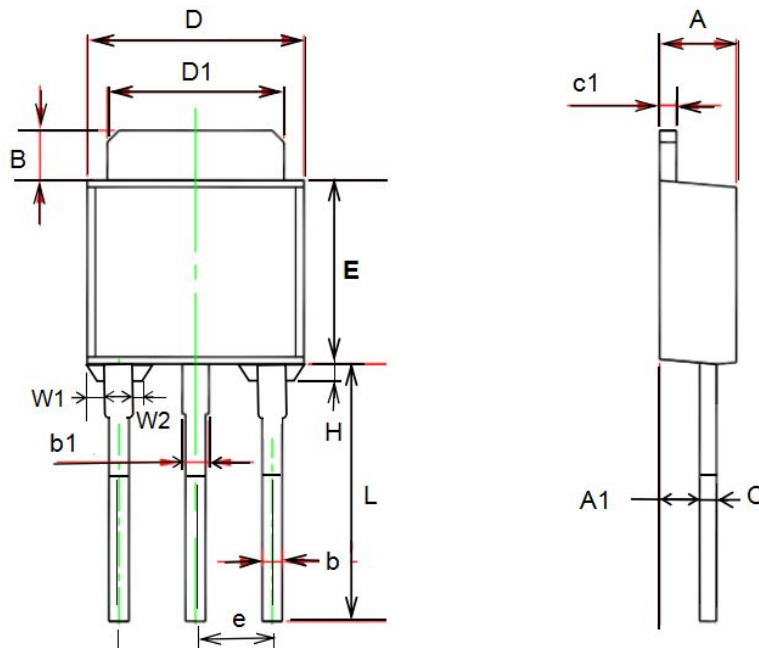

TO-251S 封装机械尺寸 TO-251S (IPAK) MECHANICAL DATA

单位:毫米/UNIT: mm

符号/SYMBOL	最小值/min	典型值/nom	最大值/max
A	2.20		2.40
b	0.50		0.85
C	0.45	0.50	0.60
D	6.50		6.70
D1	5.10		5.50
E	5.9		6.20
e	2.18	2.29	2.38
L	11.00		12.40
L1	4.8		5.3
L2	3.5		4.2

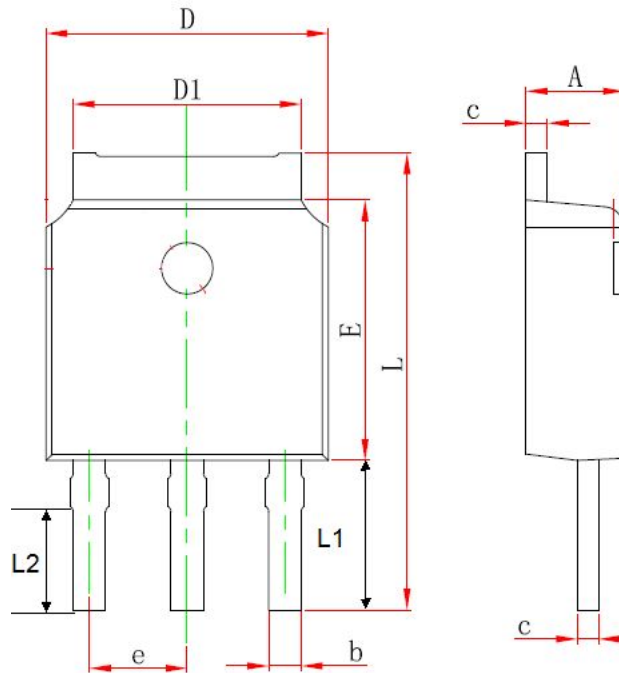

TO-252 封装机械尺寸 TO-252 MECHANICAL DATA

单位:毫米/UNIT: mm

符号 SYMBOL	最小值 min	最大值 max	符号 SYMBOL	最小值 min	最大值 max
A	2.10	2.50	B	0.85	1.25
b	0.50	0.80	b1	0.70	1.20
b2	0.45	0.70	C	0.45	0.70
D	6.30	6.75	D1	5.10	5.50
E	5.30	6.30	e1	2.25	2.35
L1	9.20	10.60	e2	4.45	4.75
L2	0.90	1.75	L3	0.60	1.10
K	0.00	0.23			

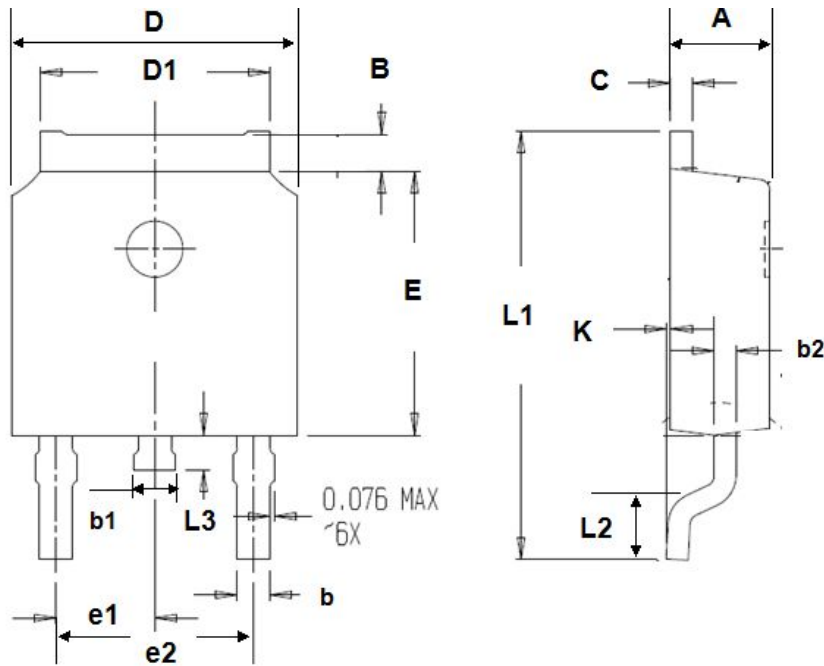

TO-252T 封装机械尺寸 TO-252T MECHANICAL DATA

单位:毫米/UNIT: mm

符号 SYMBOL	最小值 min	最大值 max	符号 SYMBOL	最小值 min	最大值 max
A	2.20	2.40	B	0.85	1.25
b	0.50	0.80	C	0.45	0.70
b1	0.45	0.70	D	6.30	6.70
D1	5.10	5.50	E	5.30	6.20
L1	9.20	10.60	F	0.50	0.90
L2	0.90	1.50	e1	2.25	2.35
L3	0.60	1.10	e2	4.50	4.70
			K	0.00	0.18

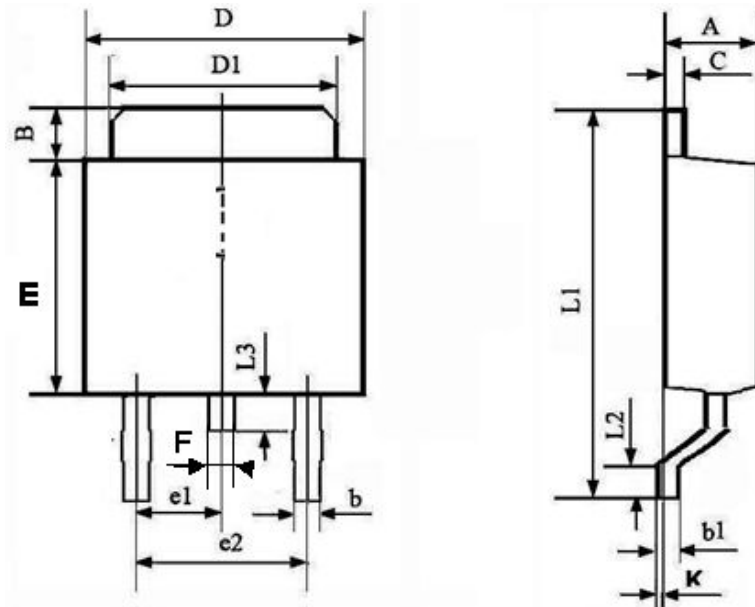

[LJ]

TO-252 编带规格尺寸 TO-252 TAPE AND REEL DATA

单位:毫米/UNIT: mm

符号 SYMBOL	最小值 min	典型值 nom	最大值 max	符号 SYMBOL	最小值 min	典型值 nom	最大值 max
A0	6.80	6.90	7.00	B0	10.40	10.50	10.60
K0	2.60	2.70	2.90	K1	2.40	2.50	2.60
F	7.40	7.50	7.60	K2	1.60	1.70	1.80
W	15.90	16.00	16.10	P1	7.90	8.00	8.10

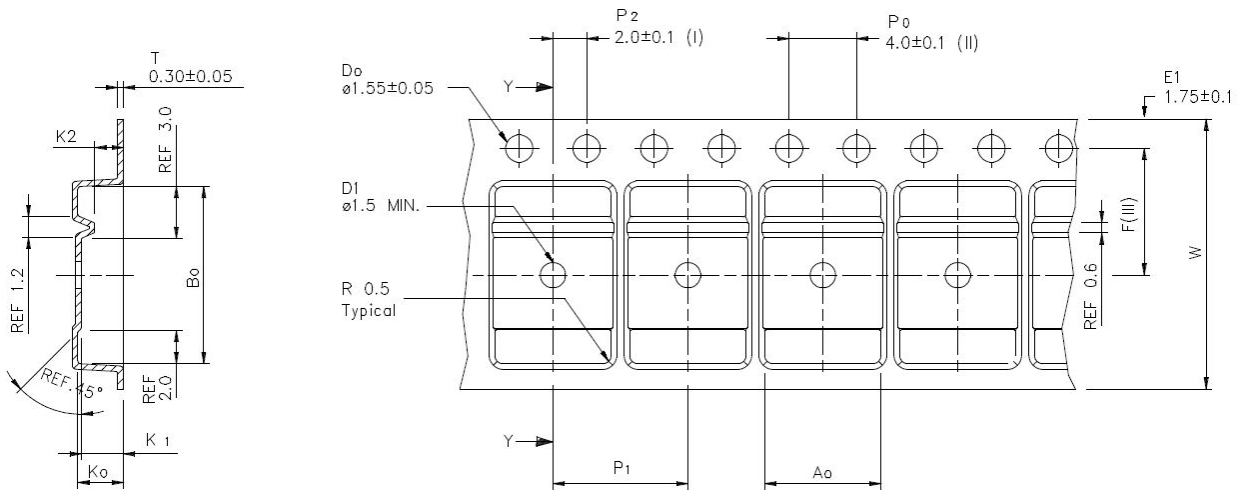

使用供带方向/USER DIRECTION OF FEED

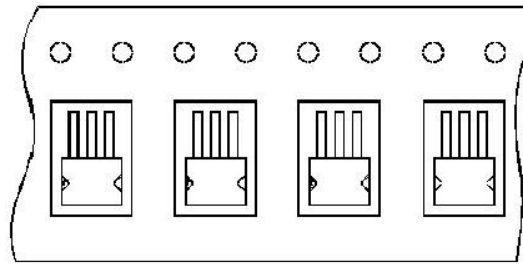

编带器件定位/UNIT ORIENTATION