

快恢复二极管/Fast Recovery Diode

FD20F20CT

●特点: 抗高浪涌性能 低正向电 大电流 低损耗 超快恢复特性 符合 RoHS 规范

●FEATURES: ■HIGH SURGE CAPABILITY ■LOW FORWARD VOLTAGE ■HIGH CURRENT CAPABILITY
■Low Recovery Loss ■Ultrafast Recovery Time ■RoHS COMPLIANT

●应用: 续流电流 超声波清洗和焊接 PFC UPS

●APPLICATION: ■FREE WHEELING ■Ultrasonic Cleaner and Welder ■PFC ■UPS

●最大额定值 (Tc=25°C)

●Absolute Maximum Ratings (Tc=25°C) TO-220/220FP

参数 PARAMETER	符号 SYMBOL	额定值 VALUE	单位 UNIT
反向电压(DC) D.C. Reverse Voltage	V _R	200	V
可重复反向电压 Repetitive Reverse Voltage	V _{R(RM)}	200	V
平均输出电流 Average Forward Current @TC=110°C,	I _{F(AV)}	10 (单侧管脚/per leg) 20 (整管/Per Device)	A
不重复正向浪涌电流 Non-Repetitive Surge Forward Current@T=10ms,Sine	I _{FSM}	100	A
结温 Junction Temperature	T _J	-55 to +150	°C
贮存温度 Storage Temperature	T _{stg}	-55 to +150	°C

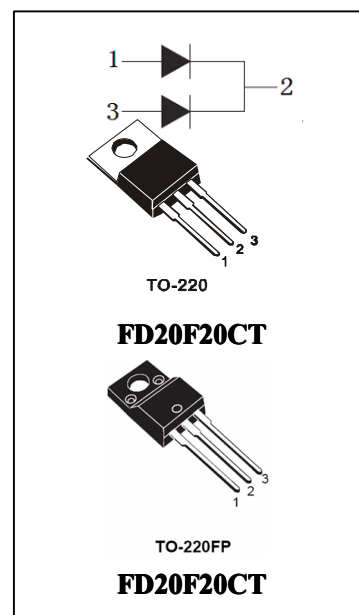

●电特性 (Tc=25°C)

●Electronic Characteristics (Tc=25°C)

符号 Symbol	参数名称 Parameter	测试条件 Test Conditions	最小值 Min.	典型值 Typ.	最大值 Max.	单位 Unit	
I _{RM}	反向漏电流 Reverse Leakage Current	V _R =200V, T _J =25°C	--	--	10	μA	
		V _R =200V, T _J =125°C	--	--	200	μA	
V _F	正向压降 Forward Voltage	I _F =10A, T _J =25°C	--	0.9	1.1	V	
		I _F =10A, T _J =125°C	--	0.86	--	V	
t _{rr}	反向恢复时间 Reverse Recovery Time	I _F =1A, V _R =30V, di _F /dt=-200A/μs	20	25	30	ns	
t _{rr}	Reverse Recovery Time	I _F =8A V _R =100V di _F /dt=-200A/ μs	T _J =25°C	--	45	--	ns
t _{rr}	Reverse Recovery Time		T _J =125°C	--	58	--	ns
I _{R(RM)}	最大反向恢复电流 Max. Reverse Recovery Current	T _J =125°C	--	6	--	A	

●订单信息/ORDERING INFORMATION:

包装形式/PACKING	订货编码/ORDERING CODE	
	普通塑封料/ Normal Package Material	无卤塑封料/Halogen Free
TO-220 条管装/TUBE PACKING	FD20F20CT TO-220-TU	FD20F20CT TO-220-TU-HF
TO-220FP 条管装/TUBE PACKING	FD20F20CT TO-220FP-TU	FD20F20CT TO-220FP-TU-HF

快恢复二极管/Fast Recovery Diode

FD20F20CT

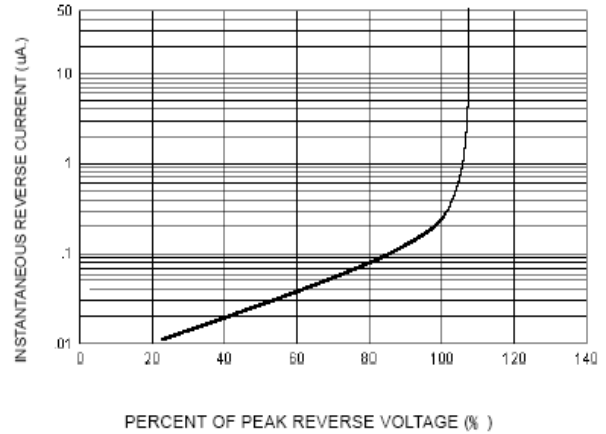
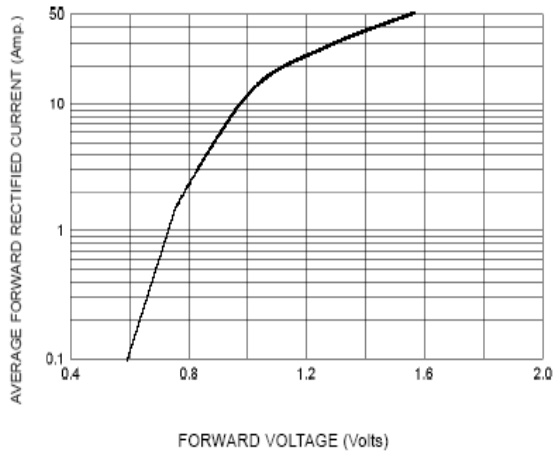

TYPICAL FORWARD CHARACTERISTICS

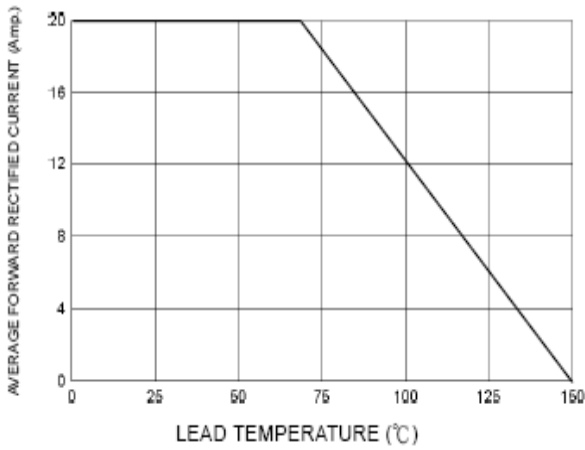

FORWARD CURRENT DERATING CURVE

TYPICAL REVERSE CHARACTERISTICS

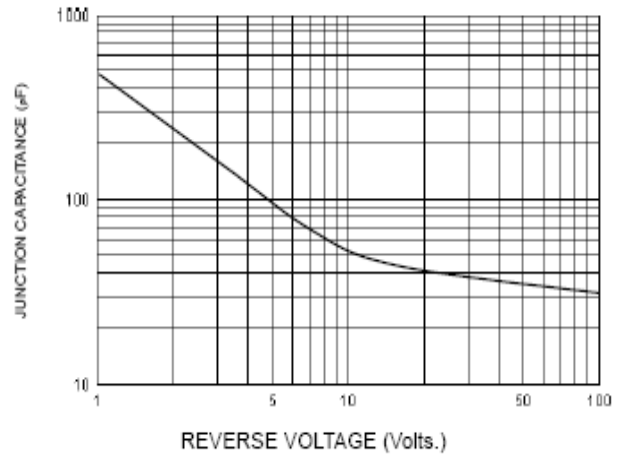

TYPICAL JUNCTION CAPACITANCE

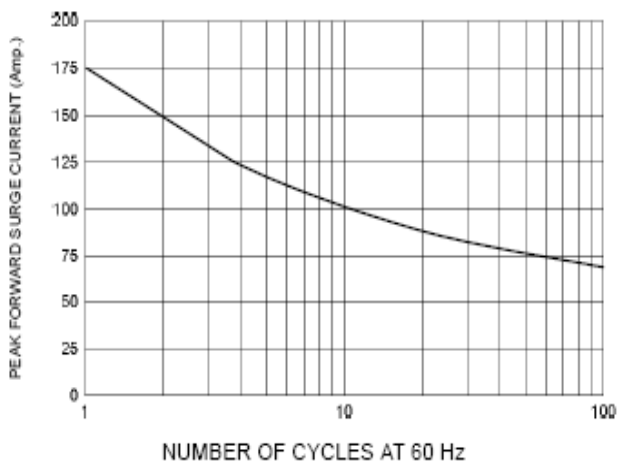

PEAK FORWARD SURGE CURRENT

TO-220 封装机械尺寸 TO-220 MECHANICAL DATA

单位：毫米/UNIT: mm

符号 SYMBOL	最小值 min	典型值 nom	最大值 max	符号 SYMBOL	最小值 min	典型值 nom	最大值 max
A	4.00		4.80	E	9.90		10.70
B	1.20		1.50	e		2.54	
B1	1.00		1.40	F	1.10		1.45
b1	0.65		1.00	L	12.50		14.50
c	0.35		0.75	L1	3.00	3.50	4.00
D	15.00		16.50	Q	2.50		3.00
D1	5.90		6.90	Q1	2.00		3.00
				φP	3.60		3.90

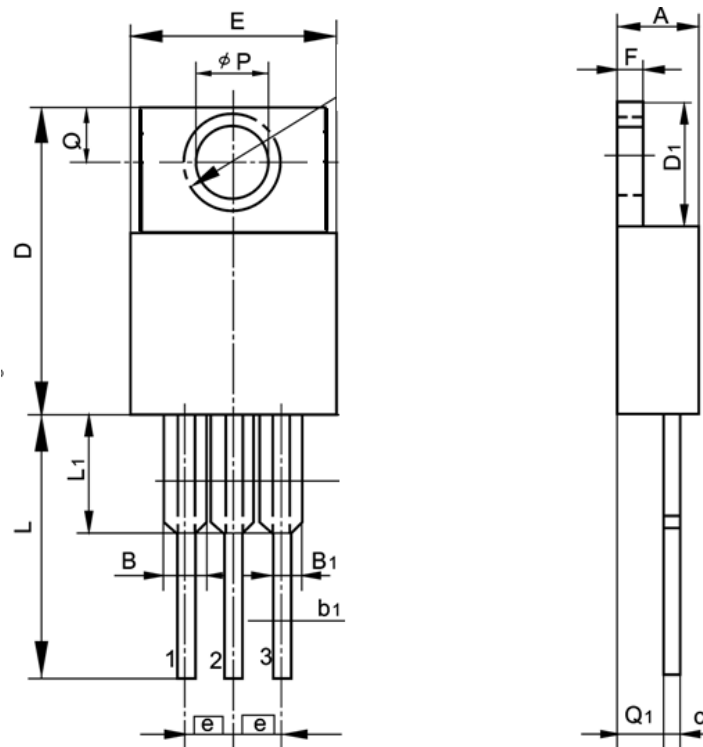

TO-220FP 封装机械尺寸 TO-220FP MECHANICAL DATA

单位:毫米/UNIT: mm

符号 SYMBOL	最小值 min	典型值 nom	最大值 max	符号 SYMBOL	最小值 min	典型值 nom	最大值 max
A	4.20		4.75	e		2.54	
A ₁	2.30		2.90	L	12.50		14.30
b	0.45		0.90	L ₁	9.10		10.05
b ₁	1.10		1.70	L ₂	15.00		16.00
c	0.35		0.90	L ₃	3.00		4.00
D	14.50		17.00	øp	3.00		3.50
D ₁	6.10		9.00	Q	2.30		2.80
E	9.60		10.30				

